



Guide to Cookware and Bakeware



THE COOKWARE &
BAKEWARE ALLIANCE

HOW TO USE THIS GUIDE

This guide is organized primarily for retail buyers and knowledgeable consumers as an easy-reference handbook and includes as much information as possible. The information carries readers from primitive cooking through to today's use of the most progressive technology in manufacturing. Year after year, buyers and knowledgeable consumers find this guide to be an invaluable tool in selection useful desirable productions for those who ultimately will use it in their own kitchens.

Consumers will find this guide helpful in learning about materials and methods used in the making of cookware. Such knowledge leads to the selection of quality equipment that can last a lifetime with sound care and maintenance, information that is also found within this guide. Any reader even glancing through the text and illustrations will gain a better appreciation of one of the oldest and most durable products mankind has every devised.

SECTIONS

• Cooking Past and Present	3
• Cooking Methods.....	5
• Materials and Construction.....	8
• Finishes, Coatings & Decorations	15
• Handles, Covers & Lids	22
• Care & Maintenance	26
• Selection Products.....	30
• CBA Standards	31
• Import Labeling	32
• Kitchen Safety	34
• Energy Conservation.....	35
• Terminology and Dimensions	36

www.cookwareandbakeware.org

As a supplement to this guide, the Cookware & Bakeware Alliance maintains a thorough collection of information on its website. Visit often for news, trends, product introductions and key market data within the cookware/bakeware industry.

COOKING – PAST AND PRESENT

HISTORY OF COOKING

Any instruction in cooking would start at the beginning, of course, with the origin of cooking. Archaeological evidence reveals that humans first applied flames to raw food as far back as the first known use of fire about 800,000 years ago. It's not known exactly why the earliest humans began cooking food, although it's assumed they preferred the change in texture or flavor.

The first cookware tool may have been a hot flat stone upon which meat could be placed in a fire. Another early cooking utensil included a skewer, which held food away from direct contact with fire to prevent burning.

Later cooking methods developed with the first use of pottery dating as far back as 10,000 B.C., which allowed food to be boiled in liquids. Techniques, such as simmering, stewing, frying, baking and roasting were introduced as ancient techniques evolved.

One of the first uses of metal was to form a cooking tool. The resulting utensils were of such value they were listed in some of the earliest wills on record and were bequeathed by their owners to the next generations.

COOKING TODAY

Cooking has greatly evolved to a point where a wide variety of cookware materials are utilized, such as aluminum, stainless steel and cast iron. Metals combined with other metals create additional products, such as stainless steel combined with copper, aluminum tin or chrome. Porcelain enamel or organic-coated steel, iron and aluminum are also available.

Like metal cookware, ceramic cookware has been available for centuries. In the last hundred years, heat-resistant glass and glass-ceramic cooking utensils emerged. With the increased popularity of microwave cooking, heat resistant plastic materials, including silicone materials, advanced into new and unique shapes for ovenware.

Cookware and bakeware manufacturers offer thousands of different products, many for general-purpose use and nearly as many for specialized use. The choices are staggering, but rest easy! This guide offers comfortable navigation through cooking methods, the properties of common materials and attributes of products to make buying and selling cookware simple.

The quality and durability of cookware and bakeware has increased markedly within the past decade assuring a better value today than any time in the past.

CURRENT TRENDS

Most consumers are stressed for time. They want cookware and bakeware that performs quickly and is easy to clean.

Cookware and bakeware choices are expanding as manufacturers seek niche products that forward-looking and sophisticated consumers will adopt.

High-temperature, engineered plastics, such as silicone, appear commonly now in bakeware and as accent trims on handles and lids.

The Guide to Cookware and Bakeware

Consumers are more adventurous when it comes to cuisines. Many different types of cooking intrigue sophisticated consumers.

Men are cooking. And, not just outside on a grill. Men are often less price sensitive when it comes to purchasing cookware and bakeware, regarding it in the same manner as other tools used to make life easier.

Cooking is now part of home entertainment. The kitchen is an integral space within a family's home. Guests feel comfortable in the kitchen, too, even pitching in to help cook.

Young people are learning to prepare foods from television cooking shows, more so now than through traditional home economics classes offered previously in American educational systems.

Celebrity chefs catch the attention of savvy consumers, which makes cooking fun and a form of art.

COOKING METHODS

HEAT TRANSFER

Cooking is essentially the transfer of heat from the heat source to a food. Simple enough by definition, yet, cooking is achieved using various forms of heat, different principals of heat transfer and is influenced by the thermal conductivity of the cooking tool used. The variables that create and affect heat transfer will be explained within the following section.

Understanding the fundamental concepts of heat transfer is essential because the way a person prefers to cook should be considered when that individual selects cookware and bakeware to use at home.

Heat is transferred in five ways:

1. Conduction
2. Convection
3. Induction
4. Radiation
5. Microwave

CONDUCTION

The transfer of heat from its source directly to cooking equipment

In conduction heating, heat spreads across the bottom of the cookware used and conveyed up its sides from the heat source. Heat is transferred directly to the food mass as the equipment heats. An example of this would be the sautéing of vegetables or stir-frying. For conduction to take place, there must be direct contact between the heat source and the pan. For this reason, conduction cooking is limited if not impossible in oven baking because there is no direct contact between the cookware and heat source.

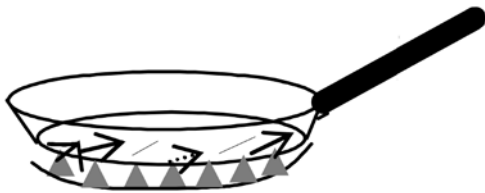

Conduction—direct heat transfer to cookware

Many foods are prepared by conduction using top-of-range cookware, so it is important that the cookware be made of a good heat-conducting material.

The conductivity of pan is dependent not only on its material but the thickness of the material. The conductive rates shown here assume equal thicknesses of the materials.

TABLE OF HEAT CONDUCTIVITY OF COMMON COOKWARE MATERIALS

(Ranked from most conductive to least.)

MATERIAL	CONDUCTIVITY
Copper.....	1.00
Aluminum.....	0.50
Steels.....	0.25
Iron and Steel (single wall).....	0.10
Porcelained Steels.....	0.16
Porcelained Irons.....	0.10
Glass Ceramics.....	0.0025
Glass.....	Less than 0.0025

Notice in the Table of Heat Conductivity *left*, that glass cookware used on a stove-top is resistant to conduction since glass is a poor conductor of heat (although glass is an excellent insulator). There is a benefit to less conductive cookware, however. The more quickly a pan heats up, or conducts, the more quickly it will cool. This is why for long, slow food preparation, for soups, stews and similar recipes, for example, less conductive equipment may be desired, in that it will hold heat for a longer period of time.

CONVECTION

The transfer of heat by means of heated air or liquids called convection currents

Heat transfer is never by convection alone. In the heating process, convection modifies or controls the rate of heat conduction. In a saucepan on the stovetop, for example, fluids in the food first begin to heat by conduction. The heat rises by convection and increases the temperature of uncooked food portions. As the hot and cool food particles intermingle, the food mass uniformly warms.

When oven baking, air near the heat source rises and circulates, only to be replaced by the cooler air. The heated air, moving in convection currents, penetrates the food, assisting in the cooking process. This is a reason why convection ovens, which use small fans to intensify the circulation of heated air, cook more quickly than conventional ovens.

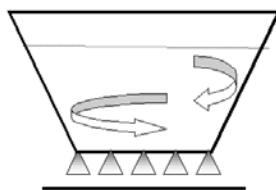

Surface Cooking

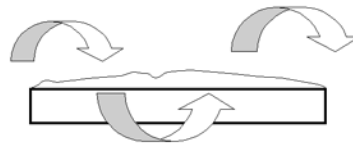

Oven Cooking

INDUCTION

The process of inducing electromagnetic currents within a metal element to generate heat

With induction cooking, an electromagnetic unit or coil beneath a ceramic cooking surface creates a magnetic electric current. This magnetic field passes through the cooking surface to ferrous (e.g. magnetic material like iron or steel) cookware. The electric current and the resistance of a ferrous metal together create heat that cooks food. Therefore, heat is induced into the cookware, not transferred to it by the cooktop.

The only heat generated is in the cookware itself, so the stovetop remains relatively cool. Thus, induction cooking is energy efficient since almost no heat or energy is wasted beyond the edge of the pan and because heating stops immediately when the pan is removed.

Cookware used for induction heating must have magnetic properties. Non-magnetic metal, such as aluminum cannot be used on induction ranges, unless it contains a core or i k of magnetic material.

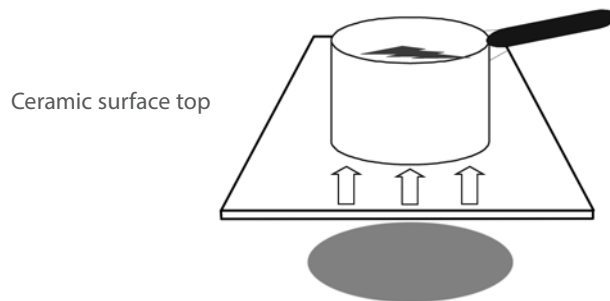

Ceramic surface top

Induction coil and associated electronics

RADIATION

The transfer of heat by electromagnetic waves

Like sound and light, radiation is emitted in waves. Radiation does not require direct contact with a heat source, liquids or air. Radiation is the reason a person can feel hot even on a cool day when they are in direct sunlight.

The heat source in a broiler or an oven produces heat waves. These heat waves are radiated to the food mass and as a result penetrate and heat the food. In a typical oven, more than half of the heat is radiant energy.

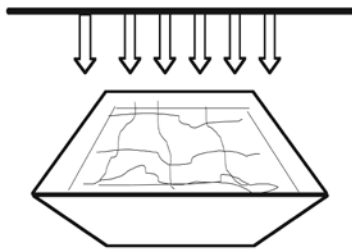

Radiating Heat Source

The transfer of radiant heat relies on the ability of cookware to absorb the radiant heat energy. Dark or blackened surfaces absorb radiant heat, while shiny, bright surfaces reflect it. Food is baked by a combination of convection, radiation and some conduction. This is why recipes placed in dark baking dishes often require less baking time than when placed in shiny pans.

MICROWAVE

The creation of electromagnetic energy waves that heat molecules within foods

Microwaves are electromagnetic currents of energy, not heat. In microwave ovens, the electromagnetic waves are created by a special generator called a magnetron. The microwaves pass into food and generate heat within liquid molecules. Liquid water molecules heat most efficiently in a microwave. Fat and sugar molecules also heat with microwave energy, but less quickly than water.

Microwaves bounce off of metallic walls in a microwave oven and penetrate food from all angles, passing directly through the cookware. For this reason, cookware that is made of glass, ceramic, plastic and paper can be used in microwave ovens. Metallic cookware would reflect the microwaves away from the food. Some microwave cookware contains a safe combination of materials for safe, controlled cooking.

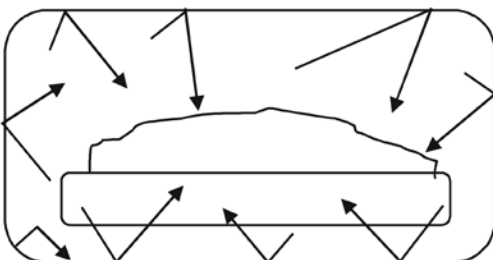

MATERIALS & CONSTRUCTION

ALUMINUM

PROPERTIES

Abundant

Economical

Efficient heat conductivity

Lightweight

Aluminum is an excellent conductor of heat making it one of the more popular materials used in the construction of cookware. Because of this quality, heat spreads quickly and evenly across the bottom, up the sides and across the cover to completely surround the food being cooked. Aluminum is a lightweight metal and easy to handle.

Aluminum is also the third most abundant element in the earth's crust, resulting in a relatively less expensive raw material. In nature, aluminum is always found in combination with other materials. An ore called bauxite is the most common source of the metal. Bauxite contains a greater percentage of aluminum than do other ores and the metal can be extracted more economically.

CONSTRUCTION

Aluminum cookware is manufactured principally by the following methods: stamping, drawing and casting.

STAMPING OR DRAWING

In the stamping or drawing method, flat sheets or circles rolled to the desired thickness are placed on a press. The press then forms the sheet metal into the desired shape. Afterward, both inside and outside finishes are applied, and appropriate handles and knobs are attached.

CASTING

Molten aluminum is poured into specially designed molds. These molds allow the thickness of the cookware to be strategically varied in different areas to maximize cooking efficiency. For instance, pan bottoms can be made extra thick for even heat absorption and the pan walls can be slightly tapered to help create circular heat movement up and down the pan. When the aluminum cools, the mold is opened and the cookware is removed. Cast aluminum cookware is often heavier and thicker than stamped equipment.

The gauge or thickness of aluminum cookware is one feature that determines its quality; the heavier the gauge (thickness), the more durable and generally, the more costly the cookware.

Gauge is usually described by a number, the smaller the number the thicker the aluminum. For example, eight-gauge aluminum is thick (.125 inches); 20-gauge aluminum is thin (.032 inch). The thickness of some pans may be labeled in millimeters. Three millimeters is equal to a little less than 0.125 inches.

FINISHES

Aluminum cookware is manufactured with a wide variety of finishes. Stamped and drawn cookware may have exterior finishes of polished natural aluminum, chrome plate, anodized (with or without color), porcelain-enamel coatings, non-stick coatings or colored organic coatings (acrylics, polyamides, etc.).

Cookware bases usually have a satin or porcelain-enamel-coated finish. Both finishes absorb heat. Cast aluminum cookware may have exterior finishes of colored porcelain-

enamel coating, polished, hammered or velva-glazed natural surfaces, colored organic coating, or hard-coat anodized surfaces.

The inside finish on aluminum cookware may be a natural finish, “sunray” or “spun” finish, high polish finish, hard-coat anodized finish or non-stick coating.

CAST IRON

The most important properties of cast iron are its heat retention and even heat distribution. It also is extremely durable. Properly cared for, cast iron will last for generations. Considered by professional chefs to be precision cooking tools, quality cast iron utensils enable precise control of cooking temperatures. The heat retention of cast iron allows for even cooking temperatures without hot spots.

Cast iron cookware should be seasoned before using. Quality manufacturers now offer cast iron that is truly pre-seasoned, with the coating of vegetable oil already applied making the pans easy to use right out of the box. Over time, cast iron cookware darkens to a black patina, a lasting, non-stick finish.

Cast iron currently is used for cookware that includes skillets, roasters and Dutch ovens, broilers, griddles and some specialty items, such as muffin and corn bread pans. These utensils are excellent for browning, frying, stewing and baking foods.

CONSTRUCTION

Cast iron cookware isn’t pure iron. Other materials, such as carbon and silicon, are mixed with the iron to produce proper hardness and durability. Iron with impurities included in it can heat unevenly and crack. Evidence of poor metal mixes includes discoloration of the cast iron, striations or smooth bright spots of “white metal.”

Cast iron cookware is produced in a sand-cast process. Quality cast iron requires sand molds made under high pressure so that their shapes can be precisely controlled. In addition to careful attention to the metal used in cast iron, the manufacturer must also control the components of the sand, which include clay and water. Patterns are pressed into the sand and the molten iron is poured into the resulting cavity. As the iron cools to its solid state and becomes a cooking utensil, the sand mold is broken apart. The sand is cleaned off the cookware and it is then smoothed and packed for shipment.

COPPER

Copper, alone or in an alloyed form, has been used in cookware for hundreds of years. Copper’s uniform heat conductivity makes it a good material for top-of-range cooking because it distributes heat evenly. Copper also retains heat longer than other metals enabling it to keep foods warm and palatable. Copper cookware also is ideal for high-heat, fast-cooking techniques like sautéing.

CONSTRUCTION

Copper cooking surfaces are usually lined with tin, stainless steel or coated with a non-stick finish because foods left directly in contact with uncoated copper may become discolored. The discoloration tends to detract from the food’s visual appeal.

PROPERTIES

Abundant

Durable

Even heat retention and distribution

Forms its own non-stick surface

PROPERTIES

Uniform heat conductivity

High heat tolerance; retains heat

Visually appealing shiny surface

An electrolytic process that deposits copper on the bottom of stainless steel cookware utilizes copper's superior heat distribution. Another manufacturing process bonds or laminates copper to stainless steel and other metals. A core of solid copper sandwiched between two layers of stainless steel is another way copper is used to distribute heat uniformly.

GLASS, CERAMIC & GLASS-CERAMIC

PROPERTIES

Excellent heat retention

One-dish for cooking and serving convenience

Chemical, odor resistance

Easy to clean

In the late 20th century, heat-resistant glass, ceramic and glass-ceramic cookware was developed that can be used for storing, cooking and serving. Major features are attractiveness, one-dish convenience, and inert, non-porous surfaces that won't absorb food odors and flavors. For easy cleaning, both glass and ceramic ovenware are available with non-stick interiors.

Baking dishes and casseroles made of these materials hold the food's heat long after it is removed from the oven. It is usually recommended to use these items at slightly lower oven temperatures for a shorter length of time because the covered cookware continues to cook foods even after it's been removed from the oven. A rule of thumb is to reduce the recommended oven temperature about 25° F (14° C).

Glass is available in a wide variety of shapes, colors and designs. It should not be used on the rangetop or under the broiler unless otherwise noted because it is sensitive to extreme heat changes. Glass cookware designed for baking can be taken from the refrigerator and put into preheated ovens after the cookware reaches room temperature. Hot glass cookware should not be allowed to come into contact with wet countertops, nor should they be placed in water while they are still hot. And, while most are rugged, glass cookware can break under impact.

Ceramics are among the most thermally shock-resistant materials ever developed and a true space-age material. Glass-ceramic was first used in rocket nosecones because the material could take the extreme temperature changes encountered in their supersonic flight from the earth's surface into outer space and back. Glass-ceramic cookware offers wide food preparation versatility. It can be used for range top cooking and is excellent for roasting, broiling or baking in the conventional or microwave oven. It can go directly from the freezer to the range top, broiler or hot oven. Glass-ceramic cookware can be immersed, hot off the stove, into sudsy dishwater for easy cleanup.

CONSTRUCTION

GLASS

Glass is a non-crystalline material manufactured by melting a combination of raw materials, including sand, soda ash, limestone, feldspar and borax. The glass used in cookware is normally melted in a large refractory furnace or tank at temperatures exceeding 2000° F. A small portion of the molten glass is drawn out of the tank and is blown or pressed into a mold. The mold essentially cools the glass, causing it to solidify. Heat-resistant glass cookware may be made of clear or tinted transparent material or opaque white (commonly called "opal" glass).

CERAMIC

Ceramic cookware is manufactured from a mixture of water, clays, fluxing minerals (often feldspar) and finely ground sand. The particular forming methods depend

largely on the water content of the mixture. A high water content (relatively liquid solution) permits casting of the ware in a mold. Lower water content results in a plastic mass that can be forced into the desired shape by a variety of methods. After forming, the ware is dried and fired (subjected to temperatures in excess of 2000° F) in a ceramic kiln to bond the components of the “body” together. Following this initial firing, the surface of the ware is coated with a glaze that, upon firing in a second ceramic kiln, develops a smooth nonporous surface much like glass.

GLASS-CERAMIC

Glass-ceramic is a special glass composition that is melted and formed like heat-resistant glass. Following forming, the articles are subjected to a special heat-treating schedule resulting in the development of a fine crystalline structure throughout the piece. It is this crystalline structure (which may be transparent or opaque) that gives the glass-ceramic its unique performance characteristics. Glass-ceramics may be white or transparent and tinted in appearance.

For glass and ceramic cookware with non-stick interiors, three layers of non-stick coating are applied to specially prepared interior surfaces and then cured at approximately 800° F.

MICROWAVE COOKWARE & ACCESSORIES

Acceptance of the microwave oven as a standard cooking tool in households gave rise to the development of cookware made especially for the microwave oven. While previous materials, like glass, glass-ceramics, ceramic and some metals work well as microwave cookware, this new category opened the field of cookware to other materials, such as plastics and paper. Containers used in microwave cooking must allow microwaves to pass through to the food.

METAL IN MICROWAVES

Contrary to popular belief, some metal can be used in microwave cooking, especially when its microwave energy-reflecting properties are used to protect foods from overheating or overcooking. This is called “shielding.” These utensils generally include a matrix material, usually aluminum, that absorbs the microwave energy and the heated metal does the cooking. This same principle applies to microwave steamers designed specifically for vegetables, seafood and eggs.

Most common metal cookware cannot be used in a microwave oven. The reason is that the metal reflects the microwave energy and the food inside the pan would not cook.

When it comes to microwave-safe cookware, look to the recommendations of both the microwave oven and cookware manufacturers.

MICROWAVE SAFE

Follow this simple test for determining the microwave compatibility of cookware:

Put one cup of cold water in a standard glass measure that is known to be microwave safe. Put the dish to be tested in the microwave oven along with the measure of cold water. Cook on HIGH for one minute. If the water has heated while the dish in question has remained cool to the touch, it is microwave-safe. If the dish becomes warm or hot, it probably should not be used in the microwave oven.

PROPERTIES

Lightweight

Convenient

Economical

While many microwave oven manufacturers recommend the use of heat-resistant glass or glass-ceramic cookware for microwave oven cooking, consumers should check manufacturer's instructions for the cookware itself. Some glass or ceramic materials may have glazed surfaces which render them unsuitable for microwave oven use.

FOR BEST RESULTS

Generally speaking, shallow containers produce better results in microwave ovens than deep ones and round shapes tend to be better than square or rectangular ones, depending on the density of the food being cooked.

PLASTICS

PROPERTIES

Convenient
Economical
Lightweight
Versatility of
color, design

Since the mid 1970's, space-age technology influenced many new developments and improvements of plastic materials. Plastics now have significantly improved durability and heat resistance leading to their use by manufacturers for ovenware and bakeware.

Plastic ovenware includes a broad category of materials with widely different characteristics. Many shapes, sizes, colors and designs of plastic ovenware are available today. Some shapes are specifically designed for small, compact microwave ovens, while others are made to accommodate certain foods.

Plastics are generally known for their use as serving, storing and packaging containers. There is a family of materials used in plastic ovenware products, which fall into two categories: thermoset plastic and thermoplastic.

THERMOSET PLASTIC

The thermoset plastic materials used for plastic ovenware have high-heat resistances that make them suitable for use from the freezer to the microwave, convection or conventional oven. An example of a thermoset plastic material is fiberglass-reinforced polyester. This type of ovenware is rigid and consequently retains the original ovenware shape, with temperatures of 400° F/204° C.

THERMOPLASTIC

Thermoplastic materials for plastic ovenware can be taken from the freezer to the microwave oven to the table. Some commonly used thermoplastic ovenware materials include polymethylpentene (TPX), polycarbonate and polysulfone.

All of the thermoset and thermoplastic ovenware products are dishwasher safe, stain-resistant, break-resistant and easy to clean. These unique characteristics have increased the popularity of plastic ovenware and continued to improve the acceptance of plastic for cooking.

CONSTRUCTION

The thermoset plastics are compression molded by using a predetermined weight of material, which is either formed or compressed into a slug or pill and is placed into the mold when the mold is in an open condition. The mold then closes and heat and pressure are applied to this plug which forces the resin into all areas of the cavity as it compresses the material.

The thermoplastic or injection molded materials are formed in an injection press in which the material passes through a heated barrel, reducing it to a liquid which is then forced under pressure into the mold itself. The mold is then cooled. Subsequently, the plastic is also cooled and solidified. The parts are then ejected from the mold.

PORCELAIN-ENAMEL ON METAL

Porcelain-enamel on metal has served the needs of mankind for centuries. Museums throughout the world contain many examples that pre-date the birth of Christ. These ancient artifacts remain as bright, clean and well defined as the day they were created.

Originally porcelain-enamel was an artistic medium for making fine jewelry and, even when it was used to make a functional object, such as an urn or small box, it was invariably fashioned in painstaking, handcrafted designs. For centuries porcelain-enameling developed as an art form, with only gold, silver, copper and bronze used as its base metal.

In 1830, a Bohemian craftsman found he could create a permanent, smooth, glassy surface on cast iron by dusting the red-hot metal with dry, powdered porcelain--- and a new era dawned. From that time on, porcelain-enamel became a utilitarian, as well as a decorative finish.

CONSTRUCTION

Porcelain-enamel is essentially a highly durable glass which, with coloring oxides and other inorganic materials, is fused to metal at extremely high temperatures. It first found its way into the kitchen as a decorative finish for wood-burning ranges and cast iron cooking equipment. Later, when techniques were discovered for applying it to sheet steel, it became a standard coating for coffeepots, roasting pans and saucepans.

In the manufacture of cookware, porcelain-enamel is applied after the metal is formed into its final shape. It can be applied to carbon steel, aluminum, stainless steel and cast iron. It is one of the most versatile finishes, offering virtually an unlimited range of colors and design effects. Today's colors include many shades of bright reds, vibrant greens, clear blues, sunny yellows and warm oranges, as well as the traditional "speckle" colors.

STAINLESS STEEL

Stainless steel cookware and bakeware is exceptionally durable. Once stainless steel has been stamped, spun or formed into a shape, it takes an extremely hard blow to dent it.

Its attractive finish resists corrosion and tarnish, and its hard, tough, non-porous surface is resistant to wear. Extremely smooth and scratch resistant, stainless steel equipment takes on an excellent polish.

Like other steels, stainless steel is an alloy—a combination of iron and other metals. What makes it different from other steels, however, is that it contains at least 11 percent chromium. It is chromium that makes steel "stainless" all the way through. Stainless steel may also contain other elements, such as nickel, molybdenum, columbium or titanium. These materials contribute special hardness, high temperature tolerance, and resistance to scratching and corrosion to the finished stainless steel alloy.

CONSTRUCTION

Stainless steel bakeware is usually fabricated of solid stainless steel. Top-of-range stainless steel cookware, on the other hand, is generally made by combining stainless with other metals, usually aluminum, copper or carbon steel. The other metals improve the cookware's heat conductivity.

PROPERTIES

Durable

Chemical, odor resistance

Stain and scratch resistance

Wide availability of colors and designs

PROPERTIES

Abundant

Durable

Resists corrosion and tarnish

Scratch resistant

Various manufacturing processes are used to combine stainless steel with these other metals. The resulting combinations are described as encapsulated or bonded bottom, two-ply, three-ply, three-ply/bottom clad, five-ply, and five-ply bottom clad.

TWO-PLY

Commonly has a stainless steel interior with another metal on the exterior. In a few instances, this arrangement is reversed with the stainless steel on the outside and a non-stick surface applied to the interior.



THREE-PLY

Has stainless steel on both the inside and outside surfaces with a layer of copper, carbon steel or aluminum forming the core.

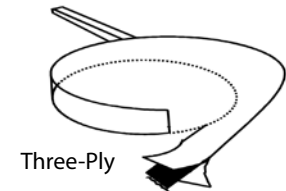

BOTTOM CLAD COOKWARE

Formed when solid stainless or three-ply, and copper is plated to the bottom or aluminum is applied to the bottom by casting, bonding or metal spraying. Five-ply/bottom-clad equipment is made by the three-ply process, with two clad layers on the bottom. Five-ply equipment is made with stainless steel on both the inside and outside surfaces with three layers of aluminum or other metals forming the core.



FINISHES

Appearance is an important consideration in the selection of cookware and bakeware. A choice of high-polish or satin finish is normally available on stainless steel ware. Either of these attractive finishes blends well with all colors and periods of kitchen décor.

Also, to meet decorator demand for color in cookware, manufacturers produce cookware with porcelain-enamel exteriors on stainless steel. But, the cooking surface is most often stainless steel, where ease of cleaning and protection of food quality are most important. Some stainless steel cookware is coated, too, with non-stick interiors.

TINPLATE

The history of tinplate in the kitchen can be traced to ancient times. Tin was widely used in Egypt, although it was not found there. Daring Phoenician sailors ventured to the British Isles, then known as the Cassiterides or Isles of Tin, to obtain this precious metal.

Tin plating is the process of plunging plates of iron into molten tin. The process was invented in Germany during the 16th century. The secret of using tin as a protective coating for metal was brought to England about 1670.

CONSTRUCTION

In our age of new concepts in materials and fabricating methods, tin-plate steel still plays an important role, particularly in the baking industry. Many commercial baking utensils are made from tin-plated steel because it is durable and possesses excellent baking qualities. The consumer market for this type of merchandise also has become important over the years because of the cookware's economy and baking qualities.

PROPERTIES

Durable

Uniform heat conductivity

FINISHES, COATINGS & DECORATIONS

Efforts to ease the homemaker's kitchen tasks have received a solid boost in recent years with the development of non-stick finishes on cookware interiors and exteriors.

A finish or decoration for cookware can be any material which, when applied, changes the basic appearance and/or function of that cookware from its natural surface.

The finish or decoration may be applied through the use of either organic or inorganic materials. It may be fused on under high heat, spray-applied and bake-dried, plated over metal, applied by an electrolytic (anodized) method, or, in some cases, silk screened or applied decal, as in the case of a decoration.

The type of finish or decoration has certain advantages in each instance, and, generally, its application will be made where factors of use, durability, heat, abrasion, design and appearance or other requirements will make one finish more suitable than another.

The finishes or decorations detailed below are not intended to be all-inclusive, yet represent those most commonly used on cookware products.

PORCELAIN-ENAMEL ON ALUMINUM OR STAINLESS STEEL

Porcelain enamel for aluminum or stainless steel is a vitreous or glassy inorganic material which bonds to metal at temperatures of about 1000° F, producing a glossy coating. Available in a variety of colors, it is usually applied to the exterior surfaces of aluminum or stainless steel.

CHARACTERISTICS

Color
Dishwasher safe
Ease of cleaning
Resistance to abrasion
Stain resistant

PORCELAIN-ENAMEL ON STEEL OR CAST IRON

Porcelain enamel for steel or cast iron is a vitreous or glassy inorganic material that requires bonding to metal by fusion at temperatures in excess of 1,400° F, producing a glossy coating. Available in a variety of colors, it is usually applied to the interior and exterior surfaces of steel or cast iron.

CHARACTERISTICS

Color
Dishwasher safe
Ease of cleaning
Resistance to abrasion
Stain resistant

ACRYLIC-ENAMEL FINISH

An acrylic-enamel finish is a thermoplastic resin coating bonded to the metal by baking at approximately 450° F. Available in many colors, it is usually applied to the exterior surfaces of aluminum.

CHARACTERISTICS

Color
Dishwasher safe
Chip resistant
Stain resistant

CHARACTERISTICS

Decorative
Dishwasher safe
Chip and scuff resistant
Stain resistant

POLYURETHANE FINISH

Polyurethane-enamel is an organic resin coating applied to metal and plastic surfaces and cured at approximately 350° F. Available in a variety of colors, it is applied to exterior metal and plastic surfaces.

CHARACTERISTICS

Decorative
Dishwasher safe
Chip and scuff resistant
Stain resistant

EPOXY FINISH

Epoxy-enamel is an organic resin coating applied to exterior metal surfaces and cured at approximately 450° F. Available in a variety of colors.

CHARACTERISTICS

Colorful
Decorative
Dishwasher safe
Ease of cleaning
Resistant to abrasion
Stain resistant

SILK SCREEN – PORCELAIN

Silk screening is a decorative process in which a special porcelain-enamel is forced through a design on a screen. Design is bonded to exterior surfaces of porcelain enameled utensils, and/or uncoated exterior surfaces of aluminum, stainless steel or glass-ceramic at temperatures of about 1,000° F.

CHARACTERISTICS

Colorful
Decorative
Dishwasher safe
Chip Resistant
Stain resistant

SILK SCREEN – ACRYLIC

Silk screening is a decorative process in which a special ink or paste is forced through a design on a screen, bonded to the surface at temperatures of about 450° F. It is applied to exterior uncoated surfaces of aluminum or stainless steel, or exterior surfaces which have been painted with an acrylic finish.

CHARACTERISTICS

Bright
Dishwasher safe
Ease of cleaning
Hard

PLATE FINISH

This finish encompasses an electrolytic deposition of copper nickel and chrome to a base metal, such as carbon steel, aluminum, copper or brass.

TIN FINISH

A tin finish may be applied either by electroplating or by wiping melted tin onto the base metal, usually steel, copper or cast iron.

CHARACTERISTICS

Good heat conductivity
Protective coating

ANODIZED FINISH

Anodizing is the process whereby the natural oxide film of aluminum is increased electrochemically in thickness to give it a hard non-oxidizing finish. The oxide film can be dyed and sealed to give a colored surface on aluminum cookware covers, bakeware, specialty items, giftware, etc.

CHARACTERISTICS

Hard
Heat absorbent
Chip and peel resistant
Scratch resistant
Stain resistant
Protective coating

DECALOMANIA

Decalomania is a printed design that utilizes a porcelain frit, which permits bonding to a metal at a temperature of about 1,000° F, thereby producing a glossy appearance. It is available in many designs and applied to exterior surfaces of porcelain-enameled utensils and/or uncoated surfaces of aluminum, stainless steel or glass-ceramic.

CHARACTERISTICS

Abrasion resistant
Colorful
Decorative
Dishwasher safe
Ease of cleaning
Stain resistant

NON-STICK – HIGH TEMPERATURE RESIN FINISH

Non-toxic plastic resins capable of withstanding cooking or baking temperatures, such as a polyamide-imide sulfide, occasionally containing a percentage of fluorocarbon resins for better non-stick. These materials are applied to specially prepared metal surfaces and baked on to the interior surfaces of metal cookware and bakeware at temperatures ranging from 600° to 800° F.

CHARACTERISTICS

Chemically inert
Colorful
Dishwasher safe
Ease of cleaning
Non-stick

NON-STICK – SILICONE AND SILICONE-POLYESTER FINISHES

These non-toxic, synthetic resins are typically applied to bakeware almost exclusively. They are not designed or formulated to withstand the direct high heat that cookware endures on top of stoves. They are designed to release high sugar content baked goods easily and to be dishwasher safe.

CHARACTERISTICS

Colorful
Ease of cleaning
Excellent Gloss
Non-stick

NON-STICK – FLUOROPOLYMER FINISH

Fluorocarbon resins are solid non-toxic plastic polymers that have inherent non-stick properties.

PTFE or fluoropolymer formulations of non-stick coatings are found almost exclusively on cookware used on top of the stove. The active ingredient in the coating is a compound known as polytetrafluoroethylene, a waxy solid that is the most slippery substance yet discovered—more slippery than even wet ice. This compound is what gives fluoropolymer cookware finishes their ability to release foods. In general, silicone non-stick finishes are less costly than fluoropolymer-based finishes.



CHARACTERISTICS

Dishwasher safe
Ease of cleaning
Non-stick
Stain resistant

Most aluminum cookware has a non-stick finish applied. Aluminum is easy to prepare and its conductivity make the curing process fairly quick and inexpensive. On the other hand, stainless steel is more difficult to coat with non-stick coatings. The surface usually has to be extensively prepared to accept the non-stick coating. Stainless is less conductive than aluminum so cure times are longer and hence more expensive. In addition, many consumers select stainless steel for its shiny look and the demand for non-stick applied to stainless is not as high as it is for aluminum pans. Non-sticks are less commonly applied to other materials such as cast iron or glass.

Some trade names identifying non-stick fluorocarbon finishes include “Teflon”, (a registered trademark of Chemours); other trade names are “Radiance”, “Eclipse”, “Excaliber”, “Quantanium” and “Halo”.

INGREDIENTS OF A FLUOROPOLYMER NON-STICK COATING

For both silicone and fluoropolymer non-stick coatings there are at least four and sometimes five major ingredients:

1. A resin or binder that adheres to the pan surface
2. A pigment to color the coating
3. The release agent—either a PTFE or silicone compound
4. The carrier—either an organic solvent or water than “carries” the ingredients but which evaporates when the coatings is cured at high heat.
5. Optional reinforcing agents to provide wear protection

As of the printing of this guide, EPA’s position is: *“EPA does not have any indication that the public is being exposed to PFOA through the use of Teflon®-coated or other trademarked non-stick cookware. Teflon® and other trademarked products are not PFOA. At the present time, EPA does not believe there is any reason for consumers to stop using any products because of concerns about PFOA.”*

The FDA is fully aware of the EPA's initiatives and, having considered the most recent scientific information available, has reaffirmed that *"at this time we have no reason to change our position that the use of (non-stick) coatings are safe for use in contact with food as described in the applicable regulations and notifications."*

It is important to understand that PFOA is *not* part of the finished product of non-stick cookware or bakeware. While used during the manufacture of the product and while there is a small amount in the finished non-stick liquid product when it is shipped to the applicator, all of the PFOA is driven off in the curing process following the application of the PTFE spray to the pan's surface. The finished pan does not contain any measurable PFOA after proper curing.

The consumer is never exposed to PFOA while using their non-stick pan. Retailers should feel confident in reassuring their customers that proper use of PTFE-coated pans is safe.

Additional information about PFOA can be found at www.pfoa-facts.com.

APPLICATION METHODS

Three major methods are used to apply non-stick coatings:

SPRAYING.

Using air to atomize the non-stick material, the non-stick ingredients are sprayed onto the pan either automatically or by hand.

Advantages include a more dense finish. Disadvantages include lower production rate than other methods and loss of expensive coating material via overspray (spray that blows past the product).



CURTAIN COATING

Blanks (circular or square shapes of the material used for the cookware and bakeware before it is formed into cookware or bakeware in a press) pass through a curtain of non-stick coating while on a conveyer belt. Advantages are extremely fast production rates with almost no waste of the coating. One disadvantage is that special formulations are required to coat properly and the blanks must be flat. Already formed shapes cannot be coated with this technique.

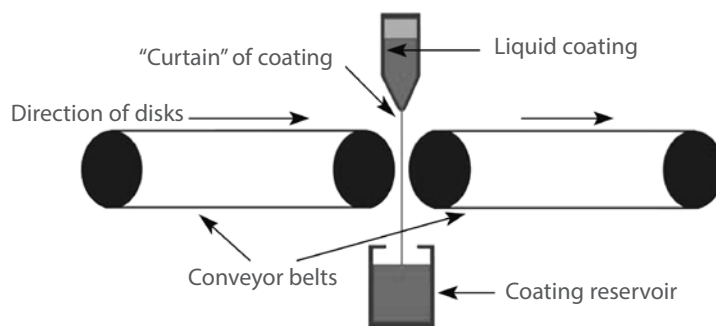

CURTAIN COATING

ROLLER COATING

Blanks (circular or square shapes of the material used for the cookware and bakeware before it is formed into cookware or bakeware in a press) pass through rollers to which the wet coating is applied. Passing through the rollers applies the non-stick, similar to rolling paint onto a wall. Advantages include fast production

rates with little coating loss. Disadvantages are noticeable striations on the finished product. Here again, already formed shapes cannot be coated with this technique. Of these three application methods the spray is most expensive followed by roller coating and curtain coating.

Coatings can be from one to three coatings in thickness. Most can also be reinforced for additional wear protection. Multi-coat systems are more costly than one- or two-coat systems.

ONE-COAT SYSTEM – The binder, pigment, release agent and the carrier all are combined in a single liquid that is applied to the pan and then cured at a high temperature.

TWO-COAT SYSTEM – Has a primer applied followed by a second coat with a higher percentage of release agent.

THREE-COAT SYSTEM – Has a primer, a mid-coat with additional fluoropolymers to enhance the adhesion of the primer to the mid-coat and the mid-coat to the top coat and a subsequent top coat. Between each of the multiple coatings, the pan is run through a "flash-off" or drying step before the final cure.

Three-coat systems can also be **reinforced**. There are two basic types of reinforcement:

1. External reinforcement - This is typically done by spraying the surface of the pan with molten stainless steel to provide greater surface area to which the coating can adhere.
2. Internal reinforcement: - This is usually accomplished by adding tiny particles of a hard substance to the primer and mid-coat. The final, topcoat of a three-coat finish is not usually reinforced. This provides resistance to wearing while maintaining optimum release characteristics.

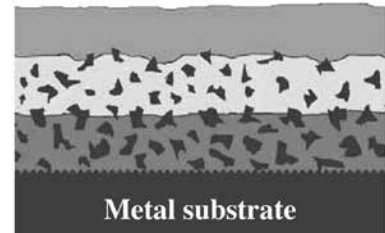

NON-STICK – PET BIRD WARNING

Overheated non-stick cookware can produce fumes that are harmful and fatal to birds. While rarely does this happen when food is in a nonstick pan, it is still recommended that pet birds never be caged in a home kitchen. Birds have sensitive respiratory systems and have been known to succumb to ordinary cooking fumes in addition to fumes driven from overheated non-sticks. All producers of non-stick coatings recommend that avian pets be kept well away from kitchens.

SAFETY CONSIDERATIONS of NON-STICK COATINGS

Non-stick coatings applied to non-commercial housewares for use in homes and restaurants to prepare, dispense, or serve foods are exempt from the Food and Drug Administration's (FDA's) food additive regulation under what is commonly referred to as the "housewares exemption."



There is one exception. **The FDA will take immediate action to protect the public's health if the non-stick coating is found to adulterate food with unsafe substances.**

Although housewares are not regulated per se, it is incumbent on the manufacturer and the retailer to ensure that each coating is formulated with ingredients known to be safe for use in contact with food and that are appropriate for the intended conditions of use. The prudent manufacturer will have testing performed by a third party laboratory and/or obtain certification from their coatings suppliers, to ensure that the non-stick coatings comply with the same FDA test criteria as coatings used in commercial applications.

Non-stick coatings produced under the housewares exemption and tested in accordance with the FDA criteria may be said to comply fully with the Food, Drug & Cosmetic Act and all applicable food additive regulations. Manufacturers should be aware that products may need to comply with other state, federal and international regulations, depending on where the products are to be marketed.

Beware of any manufacturer's claim that the FDA has "approved" or has certified a coating. Non-stick coatings can be comprised of ingredients that are "generally recognized as safe" (known as the GRAS list), but the FDA does not test, certify or otherwise approve any coatings applied to non-commercial housewares products.

NON-STICK – "CERAMIC", SOL-GEL FINISH

Sol-gel coatings, often called "ceramic coatings" (all though they are not true ceramics) have good initial release, high gloss and good stain resistance. Because they are ceramic-like, they also offer high continuous working temperatures with good abrasion and surface hardness. In 2010, approximately 90% of aluminum nonstick cookware sold is sol-gel.

Release: Initial nonstick properties of sol-gel coatings are excellent, even better than many conventional nonstick PTFE coatings. However, ceramics rely on siloxane chemistry for nonstick properties, so the release characteristic may diminish over time. Proper use and care can significantly affect the rate of decline of nonstick properties. By comparison, conventional nonstick PTFE coatings provide very good release for a longer period of time.

Abrasion Resistance: Ceramic systems are harder and less ductile than PTFE coatings.

Temperature Resistance: Ceramic coatings will survive 450°C/840°F. However, the release properties begin to diminish when exposed to temperatures above 350°C/660°F for extended periods of time. The coating remains functional because the matrix is very hard. In comparison, conventional PTFE coatings begin to deteriorate at 260°C/500°F.

Stain Resistance: When properly applied, ceramics have very good stain resistance, even in white. In contrast, PTFE coatings have less stain resistance, especially in light colors.

Colors: Ceramics can be made in a variety of colors like blue, green, red and even "Appliance White." They will maintain color at high temperatures. This is not the case with PTFE coatings and the reason why most are black or grey.

Illustrations and some information courtesy Whitford Coatings and its PKA program

HANDLES, COVERS & LIDS

HANDLES

Handles are an integral part of almost any type of top-of-stove cookware. They allow for the safe and convenient transfer of a pan and for stabilizing the pan during the cooking process. Handles are important safety component of any pan used on top of the stove.

MATERIALS

Handles can be made of formed metal, solid cast metal, various types of thermoplastics or blends of metal and thermoplastics. Handles can be polished, colored, painted, or intentionally roughened to provide a non-slip grip. Some have silicone inserts to aid in reducing heat and increasing the comfort of the handle. Handles can also be cast as part of the pan as is the case of cast iron or cast aluminum. Metal handles can go into the oven, but some plastic handles are rated up to 400 degrees and can be used in the oven as well for many recipes. Thermal cycling of plastic handles used inside the oven does have the potential to cause deterioration of plastic handles over time however.

DESIGN ASPECTS

Handles absorb heat. Heat transfer can be reduced by insulating the handle from the wall of the pan, making the handle of non-conductive plastic, or producing a handle long enough and/or shaped in such a way to dissipate the absorbed heat. Some producers of cookware use the term “cool” or some variation of that terminology, since they have designed to the handle to dissipate the heat absorbed during use of the cookware. However, no handle can be totally cool to the touch and still remain connected to the pan. Because it is difficult to know how hot the pan may be under intentional use, the CBA recommends consumers should always use a mitt, pad or other protective device when handling a hot pan.

A handle that is too-long handle can make a pan “handle heavy” and therefore unstable with a tendency to tip. This problem is most often seen in small, 1-1/2 quart saucepan where the maker has used a universal handle more properly sized for a larger pan.

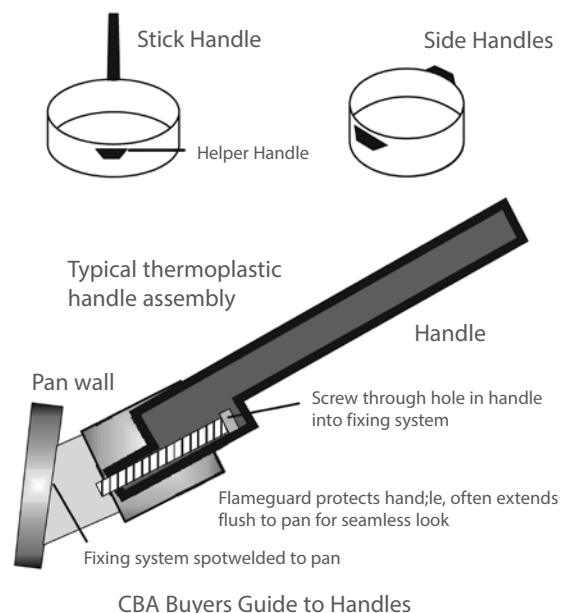

CBA Engineering Standards also call for the handle to have clearance on its underside of 1-3/16 inches at a point half way along the length of the handle. This is to give room for the user’s hand to clear any hot surfaces below the handle the pan is being used.

SHAPES AND DEFINITIONS

A long, single handle is usually known as a stick handle. A short handle, such as that on a Dutch oven is usually called a side handle. Most skillets and fry pans have a stick handle, but for those that weigh more than 11 pounds when filled with water, the CBA recommends a second side handle, sometimes known as a helper handle.

ATTACHMENT OF HANDLES AND TESTING

Handles can be riveted through the wall of the pan, attached with a screw to a handle fixing device (often integrated with a flame guard for plastic handles, to shield the plastic from direct heat from gas burners), or in some cases be designed to grip the wall of the pan, but release for storage or for use of the pan inside an oven. A handle fixing device that mates with a plastic handle is usually secured to the wall of the pan using high current spot welding. Simple one-piece handles are sometimes spot welded directly to the pan wall. See the illustrations on the previous page and below.

CBA-RECOMMENDED TESTING

The CBA recommends a number of tests in its Engineering Standards to insure that the handle and its fixing method or attachment meets stringent design criteria. There are tests performed on both hot and room temperature handles and pans that help the designer determine the optimum handle for a pan. The CBA believes that good design should allow thousands of cycles of raising and lowering pan to a level surface without loosening of the handle or its fixing system when tested with a weight 1.5 times the pan's water capacity. Additionally, the CBA recommends a torque test of 40-inch pounds be applied to stick handles to check for undesirable deflection by twisting.

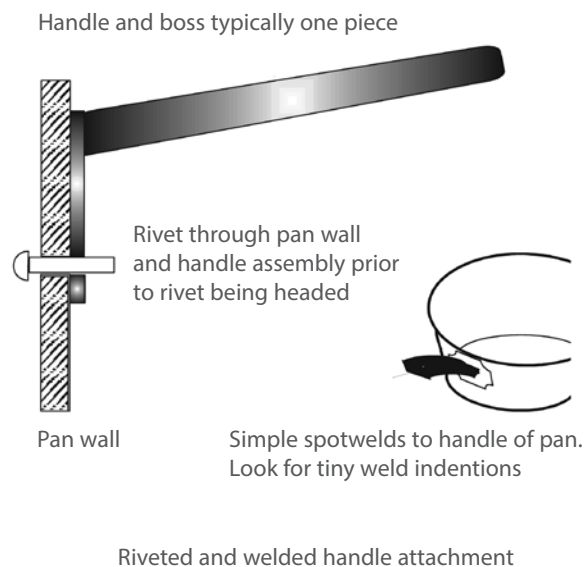

COSTS OF MANUFACTURING

The manufacturing cost of a handle includes the cost of the handle, its fixturing system and the labor and time necessary to attach the handle. Riveting requires several operations that include a punch operation to place holes in the wall of the pan, then a riveting process that places the handle and secures the rivets to affix the handle to the pan.

With plastic handles, the fixturing system is usually welded to the sidewall of the pan, and then the handle is secured with a screw that passes through the handle and into the fixture. Some form metal stick handles can be simply spot welded to the body of the pan, depending on the pan's material and gauge.

COVERS AND LIDS

Covers and lids are valuable, necessary adjuncts to many types of top-of-stove cookware. Covers and lids enable steaming, reduce cooking time, conserve nutrients in food by re-distilling steam to liquids and help control cooking time.

MATERIALS

Covers and lids fall into two broad categories: glass and metal. There are certain advantages and disadvantages to each material. Some covers even combine metal, glass and plastic.

There are also many different types and kinds of knobs and handles used on covers as well: wood, thermoplastics (high temperature resistant plastics), metal, and even silicone-impregnated metals.

Glass covers have the advantage of enabling the user to see the food's cooking process without having to lift the cover from the pan, but are often heavier than an equivalent metal cover. Metal covers are unlikely to break, but they require the user to remove them to check foods progress. Metal covers can be made of aluminum, stainless steel, copper, carbon steel or cast iron—all of the materials that cookware is made from.

DESIGN ASPECTS

Covers and lids should fit loosely. Overly tight fitting lids can turn an ordinary cooking pan or pot into an unintentional pressure cooker. When a cover is placed on a pan it should have a certain amount of “play” or looseness that will enable steam or rolling boils to escape the pan. There are specially designed knobs that can be turned to release steam, but covers should still not be too tightly fitted to their corresponding pans. Typically covers are designed with a “boss” or “lip” that is designed to fit loosely into the interior profile of the pan it is to be used or a raised shoulder lip or bead from the pan body itself captures the cover. See the cover profile illustration below.

Metal covers and lids should be free of burrs or sharp edges.

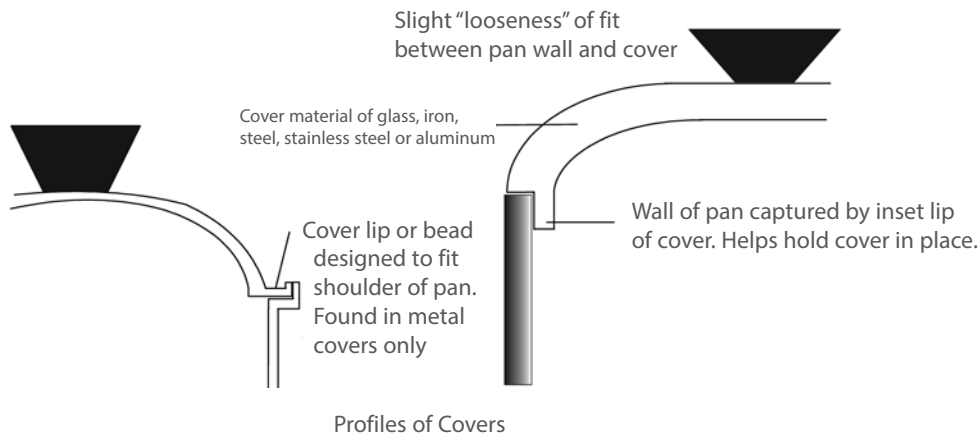

Cracking and breaking potential are considerations for glass covers. Ideally glass covers should be made of tempered soda lime or borosilicate glass, specially formulated to withstand high temperatures and sudden changes in temperatures. The edges of the covers should be thick enough to withstand chipping. If the covers are made of thin glass, then many producers wisely include a metal band—called a bezel or shroud—fitted around the perimeter of the cover to guard against edge chipping or cracks. The CBA, in its standards, also recommends that glass covers should comply with ASTM Standard C149 and all existing glass industry standards for thermal shock tests. Additionally, all metal bezels, shrouds or decorative rings should be designed and assembled in such a way that the glass isn’t scratched. Direct metal-to-glass contact should be avoided, if possible, by the use of gasket material to protect the glass—particularly where the part is attached under load to the glass (such as a knob).

Most manufacturers design their covers to fit more than one pan. For instance, a 10 inch diameter fry pan may have the same cover as does a 5 quart Dutch oven. While there are

universal lids designed to fit a variety of sizes of pans (usually 8 to 12 inches), these simply act as covers and many do not typically mesh the cover with the inside of the pan's sides, so stability of the lid is sacrificed. They are usually produced of aluminum or stainless steel.

Look for knobs and handles large enough to be easily handled by a potholder or mitt. There are a number of issues concerning the proper attachment of knobs or handles to covers and lids. These are covered below.

Some producers make covers with deep edges that are perforated to allow for pouring off cooking water from the food inside the pan. These often are made for pans that have a pouring spout or a sidewall relief area that conducts the water away from the food more easily. See illustration. Often these lids have knobs that are slightly oversized, allowing more clearance between the cover and the top of the lid, enabling the user to more easily hold the cover in place. Some of these covers are made of a mixture of glass and metals. For especially deep pots, such as stock pots, such strainer covers may have detents built into the cover and the pan itself to "lock" the cover in place. This is particularly useful with larger capacity pans. Water itself weighs over two pounds per quart or liter, and larger size pots are usually handled with two hands, not one!

KNOBS & HANDLES

There are two basic ways that a knob or handle can be attached to a cover or lid (unless of course the handle is molded into the lid; as in some cast iron and glass covers). For metal covers, the knob or handle can be spot-welded into place using high direct current (typically done with what is known as a strap handle, see illustration) or fixed mechanically with a rivet or a screw. For glass covers, the knobs are typically mechanically fixed with a screw or bolt.

If a knob is attached using a screw, the CBA recommends that the screw threads engage the knob a minimum of three full turns. Additionally, the CBA also recommends telling the consumer how to tighten the screw(s) should the knob or handle become loose.

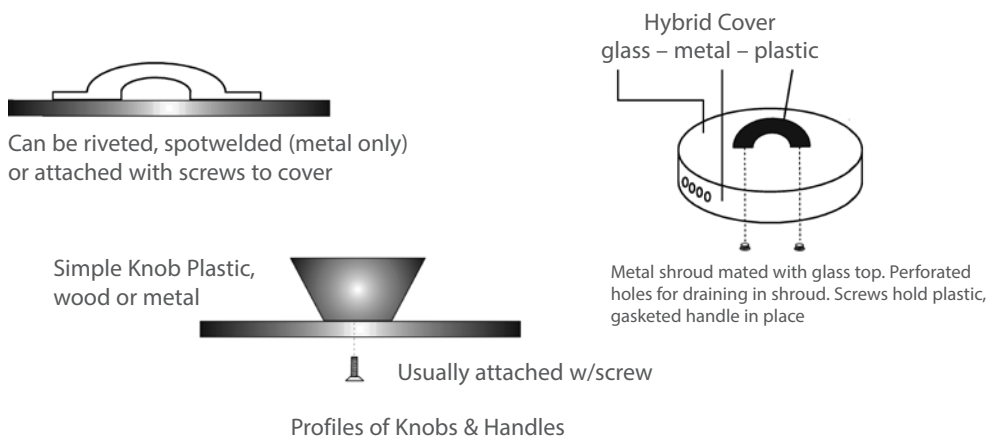

The CBA also recommends particularly that knobs attached to glass covers have gasket material installed between the knob and the surface of the glass to guard against scratching of the glass or placing the glass under undue tension, which might allow sudden shattering of the part.

Knobs designed to release steam should be designed and installed in such a manner than turning the knob "closed" can be accomplished without undue force being used.

CARE & MAINTENANCE

Cleaning dirty cookware doesn't have to be a chore. Using the proper materials and allowing for plenty of "soak" time for dirty cookware make cleaning a snap.

QUICK TIPS

Before using any new cookware or bakeware product, check the manufacturer's carton, tags and labels for special tips on use, cleaning and care.

Use a nylon or other soft abrasive cleaning pad, particularly for stainless steel and uncoated aluminum, tin plate, glass and glass ceramic utensils.

Only when foods are burned-on should the user resort to steel wool or other metal scouring pads. And, then make sure to check the manufacturer's suggestions to avoid damage to the material.

A pan that has stubborn, burned-on food should be soaked for several hours, periodically changing the mixture of hot water and liquid soap. This will help loosen the burned on crusts and enable them to be scoured away.

Don't use a metallic-scouring pad on nonstick surfaces; it will abrade them rapidly.

Metal scouring pads are not recommended for glass and glass ceramic utensils because they can scratch their surfaces

ALUMINUM

New aluminum utensils require washing in warm sudsy water to remove any residual manufacturing oils.

After use, aluminum cookware should be allowed to cool before washing or soaking. This is a simple safeguard against warping, as well as preventing accidental burns in handling. Drying immediately after washing will help preserve their appearance. Wash them each time they are used.

Undissolved salt allowed to remain on an aluminum surface may cause pitting. Add salt to liquid after it reaches the boiling point and stir to dissolve it completely. Do not allow acid or salty foods to remain in aluminum or aluminum-finished utensils for long periods of time, because this may cause pitting.

Stains and discoloration that may appear on aluminum utensils can be removed by boiling a solution of two to three tablespoons of cream of tartar, lemon juice or vinegar to each quart of water in the utensil for five to ten minutes. Then lightly scour with a soap-filled scouring pad. Cooking acidic foods such as tomatoes or rhubarb will remove the stains naturally without affecting the cooked food product. To remove stains from the aluminum exterior, use a non-abrasive cleanser.

Cooking utensils made of wood, plastic or smooth-edged metal are recommended for use in aluminum cookware. Sharp-edged tools, such as knives, mashers and beaters may scratch aluminum.

Automatic dishwashing may increase the amount of staining when the high heat of the drying cycle is added to minerals naturally present in water and the chemicals used to

purify water. For that reason, hand washing may be preferred to preserve the attractive finish of aluminum cookware.

Coated exteriors and interiors can generally be washed in automatic dishwashers. However, care should be taken when loading them into the dishwasher to avoid marring or scratching the coating.

CAST IRON

Today, most quality cast iron cookware is seasoned to a black patina at the foundry, ready for the consumer's use right out of the box.

If cast iron cookware is gray in color, the natural color of unseasoned cast iron, proceed to the directions below.

If the cast iron cookware has rust, do not despair. Although rust isn't harmful to your health, it will give a metallic taste to food. Simply scour off the rust with steel wool or an abrasive pad and proceed to the instructions below.

After washing the utensil with warm water, dry with a towel and apply a thin coat of vegetable oil and place in a 350°F oven for about an hour and let cool. Over time, the utensil will darken to a black patina. Continued use and proper care of cast iron will maintain the non-stick attributes of the cookware.

In cleaning cast iron cookware, it is important to avoid removing the cherished black patina that defines a well-seasoned pan. After cooking with your cast iron cookware, clean the utensil with hot water and a stiff brush. Never use harsh detergents to clean iron as it will remove the seasoning. Scouring or use of an automatic dishwasher will damage the seasoning and possibly result in rust. Avoid putting very hot cast iron into very cold water. The resulting thermal shock can cause it (and all metals) to warp or crack.

Towel dry your cast iron thoroughly. Some cooks simply place their cast iron on a warm stove burner for a few minutes to drive all the moisture away. While the utensil is still warm, immediately wipe a light coat of vegetable oil on all of the interior and exterior surfaces. A light oiling between uses will also preserve cast iron's seasoning.

Store your cast iron in a cool, dry place. If you have a lid for the utensil, place a folded paper towel between the lid and the utensil to allow air to circulate, or store the lid elsewhere.

Porcelain enamel coated cast iron cookware does not require seasoning. Hot sudsy water and thorough rinsing will keep them clean and shining.

COPPER

Copper can be easily polished with various commercial copper cleaners. A mixture of flour, salt, lemon juice and ammonia or a mixture of vinegar and flour are two other methods of keeping copper cookware shiny.

Tin linings may wear off with frequent use; the cookware can be re-tinned.

GLASS, CERAMIC & GLASS-CERAMIC

Check the manufacturer's recommended care and use instructions before using any glass, ceramic and glass-ceramic bakeware.

These items are usually cleaned with hot sudsy water and soaked if food has been burned on the item.

Avoid knives, sharp kitchen tools, scouring pads and abrasive cleaners so that surfaces retain their original smooth finish. This is especially important for ovenware with non-stick interiors. Nylon and plastic scrubbers are acceptable for stubborn sticking problems.

NON-STICK FINISHES

Non-stick cookware and bakeware should always be washed before its first use. Most non-stick finishes benefit from a small amount of cooking oil rubbed into the surface for the initial use as well.

Use warm water, liquid dish soap and a soft, non-abrasive sponge or dishrag to clean.

Extreme heat can be damaging to non-sticks. Using low to medium heat will preserve food nutrients, as well as protect the non-stick finish. Make sure that food, oil or water is in the cookware before heating unless the recipe calls for preheating the pan before adding food. Aluminum non-stick pans heat very quickly.

Even though many non-sticks can withstand the occasional swipe with a metal utensil, the finish will last longer if nylon or wooden utensils are used. Sharp knives will pierce any non-stick finish quite easily.

Foods should not be stored in non-sticks (or any cookware for that matter). Non-sticks can stain if left in contact with some foods.

Non-stick cookware should cool before it is immersed in water.

Some non-stick cookware is dishwasher safe, although the high heat drying cycle of the dishwasher will degrade the non-stick finish over time. Additionally, dishwashers are hard on wooden handles, particularly and some anodized finishes on the exterior of cookware. Hand washing is quick with non-sticks and is preferred, all though most consumers use the dishwasher anyway.

If burned, residue collects on the non-stick surface. A solution of three tablespoons of household bleach, one tablespoon of dishwashing liquid in one cup of water will usually remove the residue, especially if allowed to soak for an hour. The surface should be reconditioned with a light wipe of cooking oil before using it again.

PLASTICS

Wash the cookware thoroughly in hot sudsy water before first use.

All plastic ovenware is easy to clean in the dishwasher or by hand washing. However, all ovenware requires extra cleaning effort if food is allowed to burn. In such cases soak the plastic ovenware in liquid dish soap and water, and then remove the food with a nylon or plastic scrubber. In order to avoid damage to the surface, do not use an abrasive cleaner, scouring pads, strong solvents or sharp kitchen tools.

PORCELAIN-ENAMEL ON METAL

Cleaning porcelain enamel is easy. Burned on foods or other stubborn stains can be removed by soaking or by using a non-abrasive cleanser and a nylon or other non-abrasive

scrubber. All porcelain enamel utensils that have a non-stick finish applied to the interior surface are safe in modern dishwashers.

Do not use porcelain enamel cookware over high heat for a prolonged time; extreme high temperatures may cause the porcelain to melt.

Don't use porcelain-enamel pans on top of smooth glass cook tops. In case of overheating the glass porcelain can fuse with the glass cook top, risking an expensive replacement of the top.

STAINLESS STEEL

Stainless steel is one of the easiest materials to clean and to keep clean. Washing by hand in hot sudsy water or in a dishwasher usually is the only requirement for keeping stainless utensils bright and shiny. Prompt drying will prevent water spots.

Wash the utensil thoroughly in hot sudsy water to remove any manufacturing oils and polishing compounds.

Light scouring with a non-abrasive household cleaner and a nylon scouring pad or a commercial stainless steel cleaner will removed stubborn burns on the interior surfaces.

High heat may cause a mottled, rainbow-like discoloration commonly called "heat tint".

Cooking certain starchy foods—such as rice, potatoes or peas—may cause a stain on the inside of the pan. Both of these can be removed easily with any one of a number of readily available stainless steel cleaners. Undissolved salt will "pit" steel surfaces. Add salt to liquid after it reaches the boiling point and stir to dissolve completely. Do not allow acid or salty foods to remain in stainless steel for long periods of time.

With normal use, a stainless steel utensil will not dent, warp or chip. It thrives on exposure to air, so it is an attractive utensil to display in the kitchen.

TINPLATE

Very little care is required in using tin-plate bakeware. This steel-based material is highly resistant to denting and scratching. Tinplate provides the necessary protection that helps the steel resist rusting and staining.

Soaking in warm water with liquid soap generally removes most food residue.

SELECTING PRODUCTS

Whether a buyer for the retail floor or a consumer looking for specific products, the following considerations are helpful in the selection and purchases of cookware or bakeware.

Cooking utensils with flat bottoms or ones with concave bottoms designed to flatten on heating, straight sides and snug-fitting covers are more efficient in the use of energy than other shapes. Heat enters the pan directly and is retained.

Most flat-bottomed, warp-free cookware may be used on many of the smooth-surface, ceramic-glass cooking tops. Check the range manufacturer's instructions. Avoid colored bottoms as these can fuse with the glass top if they are overheated.

Cookware should be durable enough to withstand daily use. Cooking equipment should be made of a material that will not affect the color, flavor or nutritive values of foods being cooked.

Knobs and handles should be made of a sturdy, heat-resistant material, preferably with a flame or heat guard for cool handling. Attachments should be strong enough to support the weight of the cookware when it is filled and should be securely attached.

Cookware should resist tipping whether full or empty.

Construction and finish should make cookware easy to clean. Look for flaws, interior seams, crevices or rough edges that could harbor food residue or bacteria.

Buy the best quality cookware the budget will allow. Most kitchen equipment is used frequently and should be durable enough to last many years. Carefully read all labels, tags and manufacturers' pamphlets for use and care information. File these instructions for future reference.

The appearance of cookware, its color, style and finish, should be pleasing.

Versatile sizes should be selected to accommodate many cooking tasks. Use small pans for small quantities and larger pans for larger quantities of food. Top-of-range cookware is often sold in sets comprising the most common sizes. Keep in mind, sets may be less expensive than the same number of items purchased individually.

THE CBA STANDARDS PROGRAM

When selecting cookware and bakeware products, look for the CBA Standards seal on product packaging or written indication of membership with the Cookware & Bakeware Alliance (CBA). It's a sign of quality and assurance.

Alliance members stand behind their products with reliable warranties. Consumers are often tempted by "lifetime" guarantees only to be surprised, when a warranty fulfillment is needed, that the manufacturer has exited the marketplace. CBA members are devoted to the cookware and bakeware industry on a long-term basis, with some companies over a hundred years old.

CBA-member companies are devoted to manufacturing excellence, constantly testing new materials and new manufacturing techniques to bring to consumers the highest quality cookware possible. To a large extent, this means that quality, CBA-member-produced products almost never wear out.

The men and women who work in the cookware and bakeware industry are important partners of the CBA manufacturers. These individuals are committed to producing the highest quality in products. Their employers are, in turn, committed to their safety and welfare, frequently going beyond governmental regulations to ensure excellence in the workplace.

Finally, CBA members are committed to proper stewardship of the environment. Almost every member is engaged in recycling and waste reduction programs designed to reduce pollution and wastefulness of raw materials.

The Cookware & Bakeware Alliance, founded in 1922, promotes excellence in cookware manufacturing and service to consumers. Member manufacturers of CBA make a firm commitment to principles of consumer protection, manufacturing excellence, the health and safety of the industry's workers and appropriate stewardship of environmental resources.



IMPORT LABELING

THE LAW

The United States Customs Service states that products imported to the U.S. must be labeled clearly with the country of origin. Failure to properly label can result in delays in clearing customs. A marking duty penalty of 10 percent of the customs value can also be assessed in addition to expensive marking at the point of entry. The law states:

Each imported article produced abroad (is) to be marked in a conspicuous place as legibly, indelibly, and permanently as the nature of the article permits, with the English name of the country of origin, to indicate to the ultimate purchaser in the United States the name of the country in which the article was manufactured or produced.

Note the key requirements of the marking:

Conspicuous – Not hidden, but visible to casual inspection

Legibly – Large type with enough contrast to enable the average person to read it

Indelibly – Not an ink designed to fade or a label with inadequate adhesive

Permanently – As the nature of the article permits—subject to reasonable interpretation

The purpose of the labeling rule is to indicate to the ultimate user the country from which the article originated. In cookware or bakeware, clearly the end ultimate user is the consumer, and not the retailer of the product.

COMMON QUESTIONS ABOUT PRODUCT MARKING

SHOULD THE LABEL BE ON THE PRODUCT OR THE PACKAGE?

Since the intent of the law is that the product's country of origin be visible to the end purchaser, it would seem that how the product is displayed to the end user should dictate its labeling. If a pan is designed to be shown without its package, then the pan should be labeled. If it is part of a set that is contained within a color package, then the package should be labeled. If there is any doubt on the final placement or retailing of the product, then both the package and the product properly labeled would comply with both the letter and spirit of the law.

HOW PERMANENT SHOULD THE LABEL BE?

Importers argue, rightly, that the producer of goods may be producing for a number of differing countries, making it impractical to die mark the country of origin. In most cases, adhesive labels can be used to mark the country of origin on the product in such a situation. Where items are exclusive to a U.S. importer, however, the argument can reasonably be made that marking should be cast-in-the-mold, etched, engraved or die-marked.

HOW SHOULD LABELS SHOW MIXED-ORIGIN PRODUCTS?

For products that are "mixed", i.e. a imported glass cover and a U.S. made pan, labeling of the cover with its origin, or language on the packaging such as "cover made in Israel, pan made in U.S.A." would comply.

CAN LABELING BE REMOVED?

There are numerous cases of retailers scraping off the adhesive label stating the country of origin. Doing so is a violation of law, but is practically unenforceable since customs typically inspects goods upon their entry and not their final destination. Manufacturers should specify adhesive of such quality that removal of proper and legal labels is difficult. The Federal Trade Commission has reached consent decrees with firms for removal of country of origin labels in the past however. (e.g. El Portal Luggage Stores, Inc.)

WHAT ABOUT "MADE IN U.S.A. LABELS?"

Made in U.S.A. claims come under the jurisdiction of the Federal Trade Commission. This agency has wrestled with this issue in the past. Provided the substantial transformation of the product occurred in the U.S., then Made in U.S.A. is permissible. The manufacturer does not have to be as certain that the majority of the raw materials entering the product were originally produced in the U.S. As a practical matter, substantial transformation would not include attaching a handle, packaging bulk produced product into individual boxes or mating pans with covers.

WHAT ABOUT "DESIGNED IN U.S." MARKING?

Certainly the place of design may be included, but it does not substitute for country of origin labeling. It can reasonably be assumed that Customs would look askance at a larger "Designed" label than a "Made in" label.

KITCHEN SAFETY

Kitchen safety can be enhanced by selecting quality, appropriate cookware for its intended use, by following good housekeeping practices, and by abiding to manufacturers' instructions when using kitchen equipment.

SELECTING COOKWARE

Choose cookware and bakeware that are durable enough to withstand normal cooking use.

Select equipment that is fitted with handles strong enough to support the weight of cookware when filled. If handles are not built in to the body of the vessel, they should be securely attached so they won't wobble or rotate on use.

Ovenware items with handle grips make pans easy to manipulate when putting them into or taking them out of an oven.

Flame guards on handles help protect them from top-of-range heat.

Well-designed handles that are balanced with the weight of the pans prevent tipping.

Covers should fit snugly so they won't fall off when moving cookware. However, covers should not fit so tightly that force is necessary to remove them.

HOUSEKEEPING PRACTICES

Pans with broken or missing handles and knobs should be repaired or replaced. Broken equipment can be accidentally dropped, causing burns and injury. Replacement parts can often be obtained from the manufacturer.

Warped or dented metal pans are not heat efficient and can develop hot spots that burn foods.

Chipped or cracked glass or glass-ceramic cookware should be discarded.

FOLLOWING INSTRUCTIONS

Improper use of cooking equipment can lead to damage to the cookware, breakage or injury.

Manufacturers instructions provide information about the properties of the cookware material, its construction, general use and care, and any cautions that should be considered when using the equipment.

When using pressure cookers and all electric appliances, follow the manufacturers' instructions exactly.

ENERGY CONSERVATION

Although energy consumed by cooking is a very small percentage of the total energy demand, energy can be used more efficiently. Here are some simple ways to reduce energy consumption in cooking.

Metal cookware heats rapidly.

Foods generally will cook faster when a pan is covered. If heat is turned off a few minutes before food is completely cooked, heat retained in a covered pan will finish the cooking. The retained heat in an oven will also continue baking if the oven is turned off a few minutes before the end of the cooking period.

Some glass cookware is made of heat resistant materials that can go from refrigerator to hot oven or microwave. Glass cookware is excellent for use as ovenware and for casseroles because glass holds heat for a long time after being removed from the oven. Glass should not be used, however, on range top burners or under a broiler.

Glass-ceramic cookware is yet another category of specialty-glass cookware. It resists thermal shock breakage to a much greater degree than heat-resistant glasses and can go directly from the freezer to the range top or broiler or in the conventional or microwave oven.

Cookware should fit the entire surface of the heating unit on electric ranges. On gas ranges, flames should not extend beyond the bottom of the cookware.

Select the right pan size for the amount of food to be prepared. A pan that is too large requires more heat than is necessary to cook the food.

Use a minimum of liquid or fat to shorten cooking time. Low heat and snug-fitting covers make "minimum moisture" cooking possible and help seal in food flavor and nutrients.

Certain styles of cookware (featuring covers with flat tops and side handles) allow for stack cooking of entire meals on a single range unit.

Reheat leftovers or breads in a covered pan or skillet on top of the range rather than in the oven to minimize moisture loss and energy use.

Use the oven for preparing an entire meal. Select meats, vegetables and desserts that require similar baking times and temperatures. Follow the manufacturers' instructions for using cookware in the oven.

A pressure cooker prepares long-cooking foods such as meats, poultry, dried vegetables and dried fruits much more quickly than they can be prepared in conventional cookware.

Colored exterior finishes on bakeware allow for baking at 25° F or 14° C lower than plain-finished cookware. Colored finishes, whether porcelain-enamel, silicone or organic resin, increase heat absorption and heat retention.

Cookware should be preheated only when recommended and then only for the shortest time possible. Metal cookware preheats rapidly in conventional cooking.

Portable electric appliances such as skillets, slow cookers and broilers may use less energy than an electric range unit.

Double or triple recipes so that the extra quantities can be frozen for later use. Thaw frozen foods before cooking or heating unless the food package or recipe instructions specify otherwise.

TERMINOLOGY & DIMENSIONS

TOP-OF-RANGE COOKWARE

This term refers to those products used for foods which cook by direct contact with the heat source (direct heat). Common household usage and a family's needs determine cookware sizes. For best cooking results and efficient use of energy, the base dimension should relate to the diameter of the heating element or burner of the household range. The standard measurements of top-of-range cookware shall be stated as follows:

DIMENSIONS

Cookware items calling for a dimensional measurement shall be measured in inches (cm) as indicated in the following: **with an allowable manufacturing tolerance of $\pm 1/4$ (6 mm).**

HOW TO MEASURE

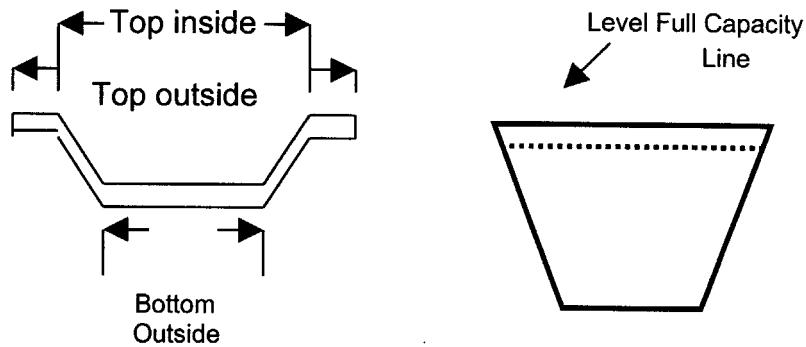

CAPACITIES

Capacities shall be stated in liquid measurements, quarts or fractions thereof (liters or milliliters) at level full, except as otherwise noted in the following: **with an allowable manufacturing tolerance of $\pm 5\%$ of total volume.**

Manufacturers are encouraged to mark the size and capacity permanently on top-of-range cookware and/or on labels.

CANNER (WATER BATH)**DESCRIPTION**

A large covered cooking utensil generally with side handles and equipped with a rack or jar holder. Must have 2 to 3 inches of headroom above the jar lid.

HOW MEASURED

Level full capacity and number of jars it will hold

AVAILABLE SIZES

20-36 quarts in increments of 1½ quarts

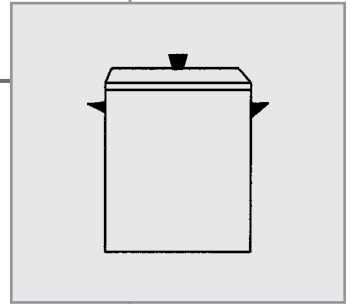
**COVERED FRY PAN****DESCRIPTION**

A deep fry pan or skillet with a cover. Also called a chicken fryer when diameter is 10 inches or larger

HOW MEASURED

Top outside dimension. The bottom outside dimension may also be stated

AVAILABLE SIZES

10 inch or larger (top dimension)

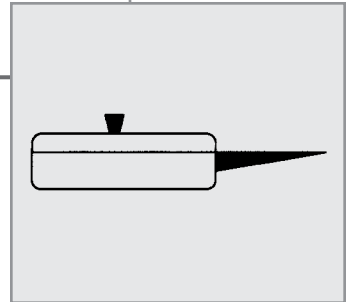
**COFFEE MAKER****DESCRIPTION**

A utensil used for making coffee by the percolator, drip, vacuum, espresso, or boiling method

HOW MEASURED

Number of finished brew portions based on 5 ounce servings

AVAILABLE SIZES

Range of 2 to 48 serving portions

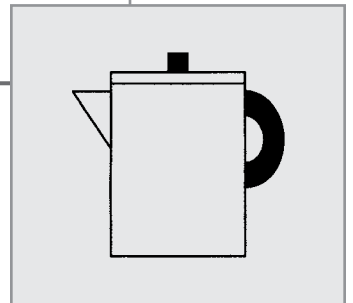
**CREPE AND OMELETTE PAN****DESCRIPTION**

A shallow, uncovered pan with sloping sides and having one long handle

HOW MEASURED

Top outside dimension

AVAILABLE SIZES

6 inches or larger

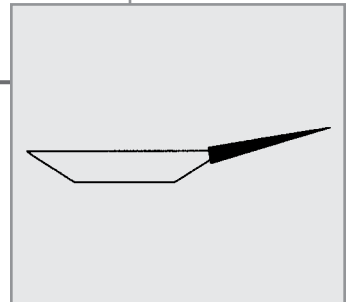
**DOUBLE BOILER****DESCRIPTION**

Two saucepans or a saucepan and an insert made so that one may be inserted on top of the other. Equipped with a cover.

HOW MEASURED

Level full capacity of insert and bottom pan listed separately. If only one capacity is listed, then both are same.

AVAILABLE SIZES

1-½ quarts or larger in increments of half quarts

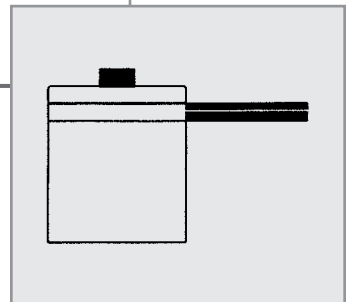

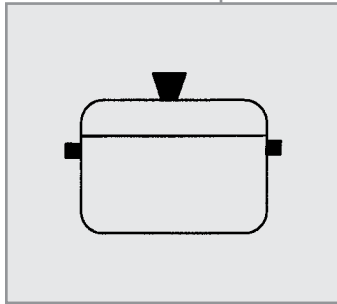

DUTCH OVEN

DESCRIPTION

A deep cooking utensil with a close fitting cover and two side handles, sometimes equipped with a rack or trivet

HOW MEASURED

Level full capacity

AVAILABLE SIZES

4 quarts or larger in increments of half quarts

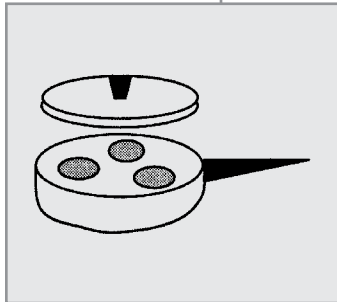

EGG POACHER

DESCRIPTION

An insert device with shallow cups or it may be a covered pan with such an insert device

HOW MEASURED

AVAILABLE SIZES

1 to 6 eggs

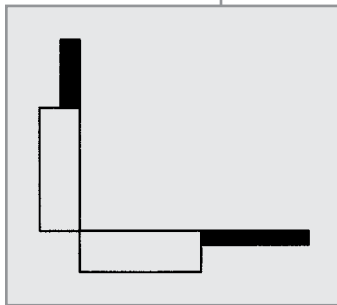

FOLDING OMELETTE PAN

DESCRIPTION

Two shallow rectangular or semi-circular pans attached by hinges, one acting as a cover for the other. Each pan shall be equipped with one handle

HOW MEASURED

Level full capacity

AVAILABLE SIZES

2 cups (each pan) or larger

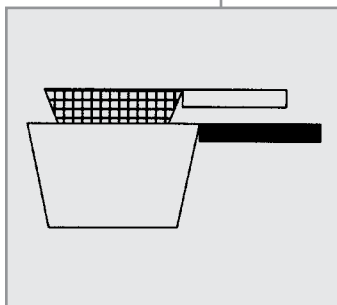

FRENCH FRYER

DESCRIPTION

An uncovered cooking utensils with a perforated, meshed or sieve-like insert basket with one handle

HOW MEASURED

Level full capacity of pan

AVAILABLE SIZES

2-1/2 and 3 quarts in increments of half quarts

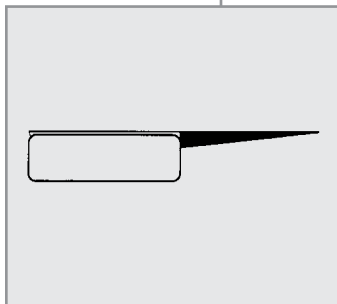

FRY PAN OR SKILLET

DESCRIPTION

A shallow, covered or uncovered pan with one long handle. (A small side, helper handle is optional.)

HOW MEASURED

Top outside dimension. The bottom dimension may also be stated

AVAILABLE SIZES

6 inches or larger top dimension

GOURMET AND SAUTÉ PAN**DESCRIPTION**

A shallow, uncovered pan with one long handle, usually with sloped sides. (A small side handle is optional.)

HOW MEASURED

Top outside dimension

AVAILABLE SIZES

6 inches or larger

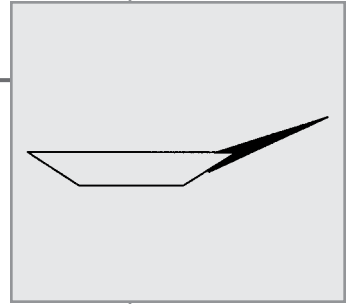
**GRIDDLE****DESCRIPTION**

A utensil with one long handle, two side handles, or bail handle, wide bottom and shallow side wall. Available in round, square or oblong shapes.

HOW MEASURED

Top outside dimension

AVAILABLE SIZES

6 inches of larger

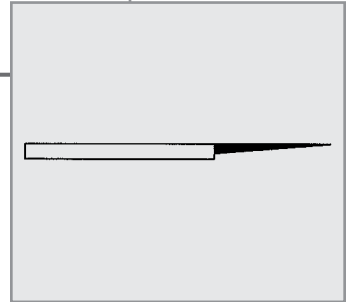
**KETTLE****DESCRIPTION**

A covered utensil with a bail handle across the top for easier lifting.

HOW MEASURED

Level full capacity

AVAILABLE SIZES

6-1/2 to 23 quarts or larger in increments of quarts.

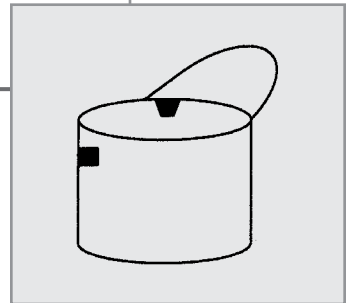
**STEAMER****DESCRIPTION**

A covered utensil similar to a sauce pot but with a perforated insert, so that food placed in the insert is raised above the small amount of water in the pot and is cooked by

HOW MEASURED

steam. Level full capacity of exterior unit

AVAILABLE SIZES

2 quarts or larger in increments of quarts.

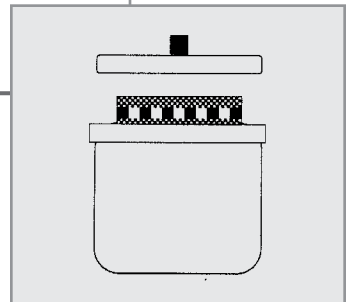
**PRESSURE COOKER/CANNER****DESCRIPTION**

A utensil with locked on cover that permits steam pressure of 5 to 15 pounds per

HOW MEASURED

Level full capacity

AVAILABLE SIZES

2 to 20 quarts in increments of half quarts.

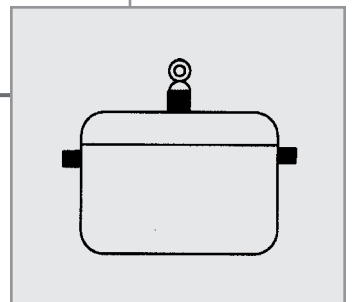

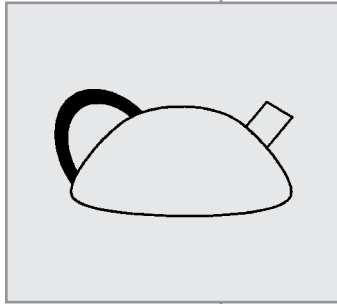

TEA KETTLE

DESCRIPTION	HOW MEASURED	AVAILABLE SIZES
A covered or closed utensil having one handle and equipped with a spout or a pouring lip	Filled to the point of overflow on level surface	1 quart or larger in increments of half quarts

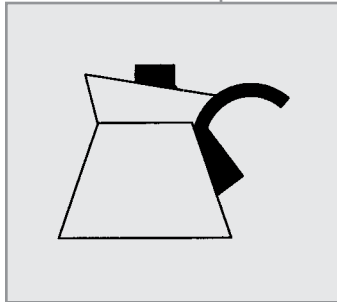

TEAMAHER

DESCRIPTION	HOW MEASURED	AVAILABLE SIZES
A utensil used for making tea by the "steep" method	Number of finished brew portions based on 5 fluid ounce servings	Range of 2 to 10 portions

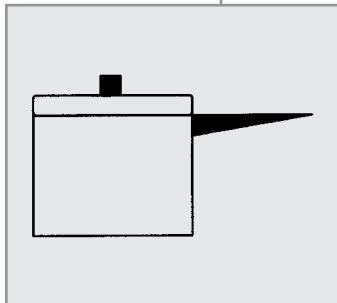

SAUCEPAN

DESCRIPTION	HOW MEASURED	AVAILABLE SIZES
A covered or uncovered cooking utensil with one long handle. (A small side handle is optional)	Level full capacity	1/2 to 4 quart in increments of half quarts

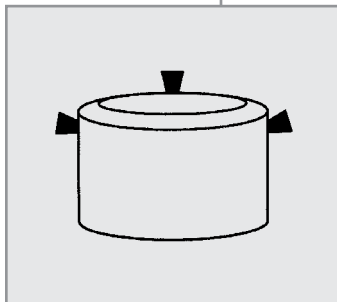

SAUCEPOT OR STOCKPOT

DESCRIPTION	HOW MEASURED	AVAILABLE SIZES
A covered or uncovered cooking utensil with two side handles	Level full capacity	3-20 quarts in increments of half quarts

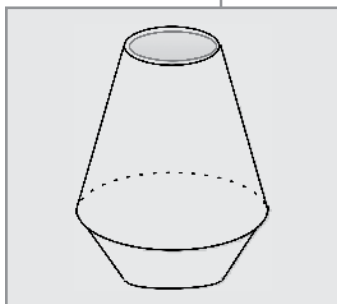

TAGINE (TANJINE)

DESCRIPTION	HOW MEASURED	AVAILABLE SIZES
A covered utensil typically used in Middle Eastern recipes with a flat base unit with a dome-shaped cover that sits on the base during cooking. The cover is designed to return condensed steam to the bottom. Typically produced in heavy gauge metals or in stoneware.	NA	Varies

BAKEWARE

TERMINOLOGY AND DIMENSIONS

The term **Bakeware** refers to those products used for foods which cook by absorbing heat from the surrounding hot air produced in an oven (indirect heat). The standard measurements for Bakeware shall be stated as follows:

DIMENSIONS

The top inside dimension for width, length or diameter shall be stated in inches (cm) **with an allowable manufacturing tolerance of $\pm 1/4$ " (6 mm)**.

The inside perpendicular dimension for depth shall be stated in inches (cm) **with an allowable manufacturing tolerance of $\pm 1/4$ " (6 mm)**.

CAPACITIES

Capacities may be stated in liquid measurements as level full capacities in quarts or fractions thereof (milliliters or liters) **with an allowable manufacturing tolerance of ± 5 percent of the total volume**.

ORDER OF STATING DIMENSIONS

The order of stating dimensions for round utensils shall be diameter by depth plus volume, and for square and rectangular utensils shall be length by width by depth plus volume.

MARKINGS

The manufacturer shall mark measurements of baking utensils permanently where applicable or at least with temporary labels.

DEFINITIONS AND SIZES

GENERAL

The definitions and sizes listed in the following sections shall be preferred in both manufacture and recipe development and are generally available in the marketplace.

CAKE PANS

A cake pan is a utensil designed primarily for baking cake. It may have a removable bottom and may be of any shape, although usually round, square or rectangular. Some types contain a central tube and have either smooth sides and bottom or a configuration designed to mold the cake sides and bottom.

RECTANGLE

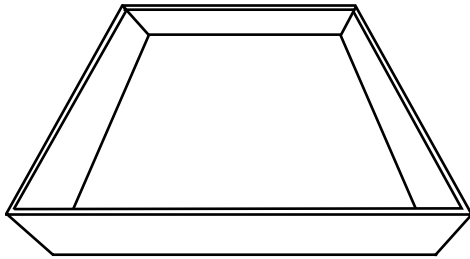

TYPICAL DIMENSIONS

INCHES	CM
10 x 6 x 1 ¹ / ₂	25 x 15 x 4
11 x 7 x 1 ¹ / ₂	29 x 18 x 4
11 ¹ / ₂ x 8 ¹ / ₂ x 2	29 x 20 x 5
11 ¹ / ₂ x 8 ¹ / ₂ x 1 ¹ / ₄	29 x 22 x 3
12 x 7 ¹ / ₂ x 2	30 x 19 x 5
13 x 9 x 2	33 x 23 x 5
13 ¹ / ₂ x 8 x 2 ¹ / ₈	33 x 20 x 5
13 ¹ / ₂ x 9 ¹ / ₂ x 2	34 x 24 x 5
14 ¹ / ₂ x 10 ¹ / ₂ x 1 ¹ / ₂	37 x 27 x 6
15 ¹ / ₂ x 9 ¹ / ₈ x 1 ³ / ₄	39 x 23 x 4

ROUND

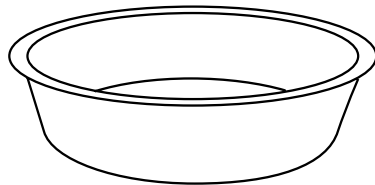

INCHES	CM
8 x 1 ¹ / ₂	20 x 4
9 x 1 ¹ / ₂	23 x 4
10 x 1 ¹ / ₂	25 x 4

SQUARE

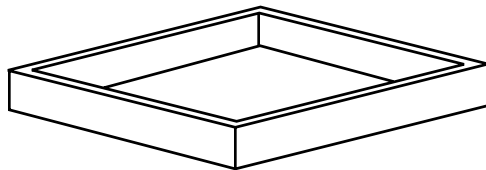

INCHES	CM
8 x 8 x 2	20 x 20 x 5
9 x 9 x 2	23 x 23 x 5
10 x 10 x 2	25 x 25 x 5

TUBE

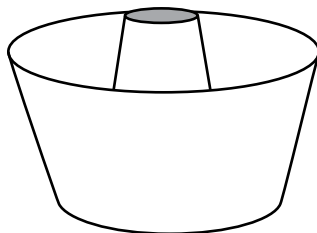

INCHES	CM
9 x 3 ¹ / ₂	23 x 9
10 x 4	25 x 10

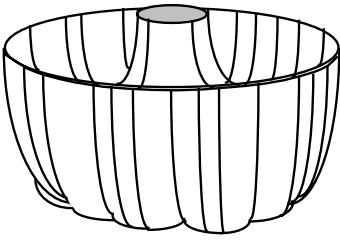
CAKE MOLD

(Bundt® Turk's Head, Guglehubf Pan) – A cake mold is a utensil with or without a central tube and a “carved” design in the sidewalls. It is designed for cakes, gelatin salads and desserts. The capacity of the cake mold shall be stated in liquid measurement in quarts or liters to a level $\frac{1}{4}$ inch from the top of the mold.

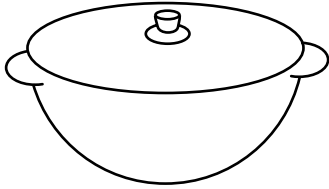
CASSEROLE

A casserole is a covered or uncovered utensil in which food may be baked and served. It may have one or two handles. The size is expressed in liquid measurement at its level full capacity. Preferred sizes are about $\frac{1}{2}$ quart (500 ml) to about 4 quarts (4 L) in increments of half quarts.

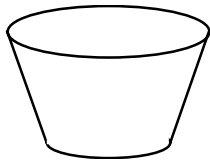
CHEESECAKE PAN

A cheesecake pan is a round, deep pan with a removable bottom. It is especially designed for making cheesecake and desserts. The measurements are about 9 x 3- $\frac{1}{2}$ inches (23 x 9 cm).

COOKIE SHEET/TRAY

A cookie sheet/tray is a flat rectangular utensil which may be open on one, two or three sides. It is especially designed for baking cookies and biscuits. The sizes for cookie sheets/trays generally are as follows:

TYPICAL DIMENSIONS

INCHES	CM
10 x 8	25 x 20
14 x 9	36 x 23
14 x 10	36 x 25
15 $\frac{1}{2}$ x 12	39 x 30
16 x 11	41 x 28
17 x 14	43 x 36
18 x 12	46 x 30

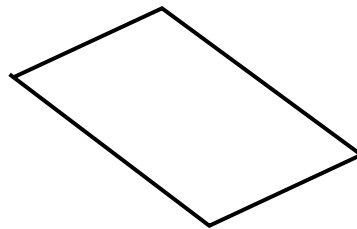
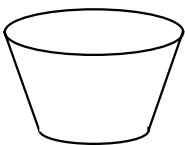
**CUSTARD DISH/RAMEKIN**

A custard dish/ramekin is a small, deep individual, bowl-shaped utensil especially designed for oven use. The size of a custard dish shall be stated in liquid measurement at its level full capacity. Sizes range from about $\frac{2}{3}$ cup to about 3 cups (175 ml to 750 ml).

JELLY ROLL PAN/TRAY

A jelly roll pan/tray or baking sheet is a shallow rectangular utensil, usually 1 inch deep. The most common size is 15½ x 10½ x 1 inches (39 x 27 x 2.5 cm).

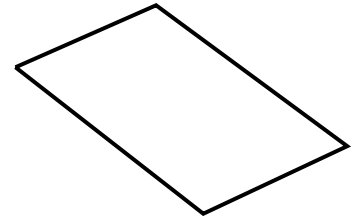

LOAF PAN/DISH

A loaf pan/dish is a deep, narrow, rectangular utensil with slightly flared sides and flat bottom, designed for oven use for baking bread, meat loaf, etc. The sizes generally available are as follows.

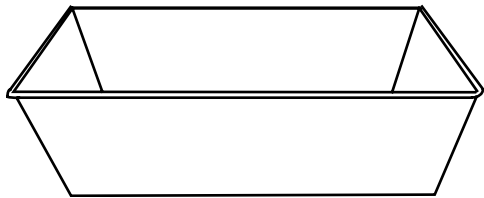

TYPICAL DIMENSIONS

INCHES	CM
7½ x 3¾ x 2¼	19 x 10 x 6
8½ x 4½ x 2½	22 x 11 x 6
9 x 5 x 2½	23 x 13 x 6
9 x 5 x 3	23 x 12 x 8
9½ x 5 x 3	24 x 13 x 8
11 x 7 x 3	28 x 18 x 8

MUFFIN OR CUPCAKE PAN

A muffin or cupcake pan is a tray-like utensil containing a number of individual cups which are formed from the tray metal (seamless) or are mechanically attached to the tray. Dimensions of cups range from 1¾ x 1 inches (4 x 3 cm) to 3 x 1½ inches (8 x 4 cm).

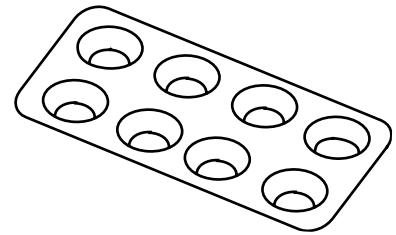

PIE PAN/PLATE

A pie pan/plate is a round, open utensil with flared sides, especially designed for baking pies. The most commonly used sizes for pie pans/plates are as follows:

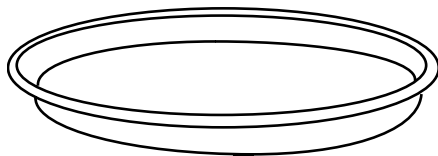

INCHES	CM
2¼ x 1¼	11 x 3
5 x 1	13 x 3
6 x 1	15 x 3
7 x 1¾	18 x 4
8 x 1¼	20 x 3
9 x 1¼	23 x 3
9½ x 1½	24 x 4
10 x 1½	25 x 4
11 x 1½	28 x 4
12 x 1½	30 x 4

ROASTING AND BAKING PAN

A roasting and baking pan is a large rectangular or oval pan (covered or uncovered) especially designed for roasting meats and poultry, and for baking. The length and width shall be measured overall outside including handles. The sizes generally available are as follows:

TYPICAL DIMENSIONS

INCHES	CM
13 ¹ / ₄ x 7 ³ / ₄ x 3 ¹ / ₂	34 x 20 x 9
13 ¹ / ₂ x 9 x 2	34 x 23 x 5
14 x 10 x 2	36 x 25 x 5
15 ¹ / ₈ x 8 ³ / ₄ x 4	39 x 22 x 10
15 ¹ / ₂ x 10 ¹ / ₂ x 2 ¹ / ₄	39 x 27 x 6
17 ¹ / ₈ x 11 ¹ / ₂ x 2 ¹ / ₄	44 x 29 x 6

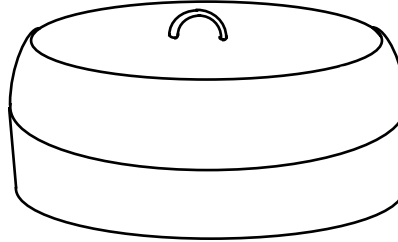

SOUFFLÉ DISH

A soufflé dish is similar to a casserole dish with sides that are vertical and fluted decoratively on the outside. The size is expressed in inches and centimeters for top inside diameter and perpendicular depth with volume at level full capacity in quarts (L). The sizes generally available are as follows:

INCHES	CM
5 ¹ / ₂ x 2	14 x 5
6 ³ / ₄ x 2 ¹ / ₂	17 x 6
7 ³ / ₄ x 2 ¹ / ₄	20 x 10

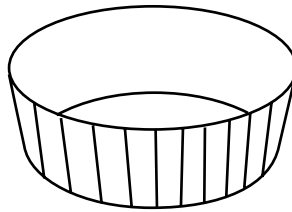

SPRINGFORM PAN

A springform pan is a round, deep pan whose side section is equipped with a lock or clamp so that it can be completely released and removed without disturbing the contents of the pan. It may have a flat or tubed bottom or both for interchangeable use. The size is expressed in inches (cm) for top inside diameter and perpendicular depth.

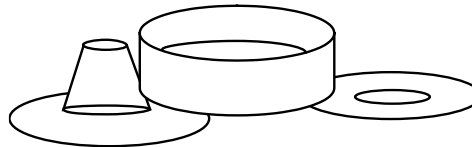

STEAK PLATTER



A steak platter is usually an oval shallow pan used for broiling steaks, chops, etc. and as a serving piece. The length and width of a steak platter shall be measured overall outside including handles in inches (cm).

SALAD OR DESSERT MOLD

A salad or dessert mold is a utensil for holding mixtures which are to be refrigerated or baked. It may be of any decorative shape or size. The capacity shall be stated in liquid measure by cups (ml) or quarts (l) level about 1/4 inches (6mm) from the top of the mold.

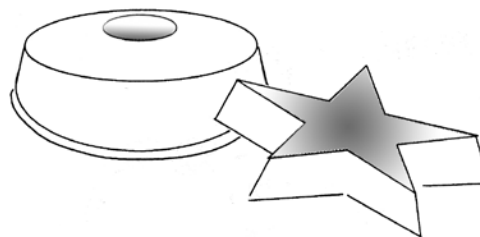

OTHER KITCHENWARE

The following miscellaneous kitchenware and pantryware items are generally available. The sizes (dimensions) or capacities (volume) are left to the discretion of manufacturers, utilizing the preceding guidelines.

Colanders & strainers	Salad bowls
Ice buckets	Mixing bowls
Bun warmers	Range sets
Canisters	Ice cube trays
Cookie guns	Lazy Susans
Cutters/cookie, biscuit	Candy/nut dishes
Broiler/baking racks	Serving trays
Water pitchers	Serving bowls
Grease containers	

MICROWAVE BROWNING DISHES

Microwave browning dishes refer to those products (with and without covers) used for browning foods in microwave ovens. A special material is applied to the underside of the cooking surface which, during a preheating time, absorbs microwave energy. The absorption of microwave energy heats the cooking surface for browning and crisping various meats or fish or breads while they are being cooked by microwave energy. The browning not only adds color but adds flavor and texture resulting from the foods contact with the hot surface.

LIQUID MEASURING UTENSILS

DEFINITION

Household liquid measures are intended for the noncommercial measurement of liquid ingredients used in preparing foods and shall have a pouring lip.

CAPACITIES

The capacities of liquid measures shall be one quart (32 fluid ounces, four cups), one pint (16 fluid ounces, two cups), or one half pint (8 fluid ounces, one cup). The capacity mark shall be near the top of the measure but sufficiently below the pouring lip to allow normal use of the container without spilling. The lip shall be so designed as to permit the measure to be filled with liquid to the capacity mark while the measure is standing on a level surface.

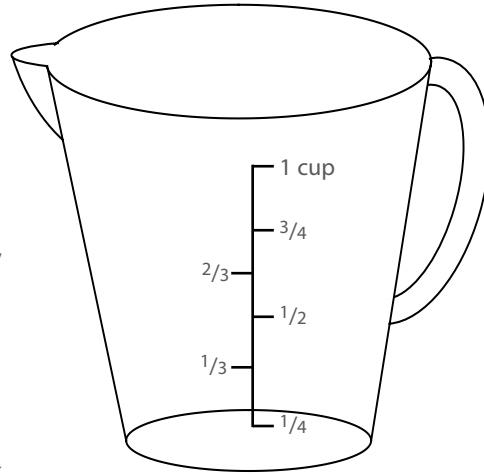

GRADUATIONS AND MARKINGS

The capacity of each measure shall be identified in cup(s) and fluid ounces. Liquid pint(s) may be included. Subdivision of 1 cup shall include only $\frac{3}{4}$ cup, $\frac{2}{3}$ cup, $\frac{1}{2}$ cup, $\frac{1}{3}$ cup and $\frac{1}{4}$ cup. The word "cup" need appear only once. Where graduations indicating both $\frac{1}{3}$ and $\frac{1}{4}$ cup subdivisions are used, the horizontal marks defining thirds shall be on the opposite side of a vertical line from the marks defining fourths of a cup. Subdivision by fluid ounces may be included and should be marked so as to avoid confusion with cup and fractional-cup markings. Markings on all liquid measure shall be durable and distinct. The value of all markings defining full capacity and fractional graduations shall be shown and shall be no less than

$\frac{3}{4}$ inches (2 cm) in length. Where graduations and markings in metric units appear in addition to the customary units, they shall be displayed in such a manner as to avoid confusion between the two systems.

TOLERANCES

The tolerances to be allowed in excess or deficiency on customary household measures shall be $\pm 5\%$ of the designated capacity of all graduations.

DRY MEASURES

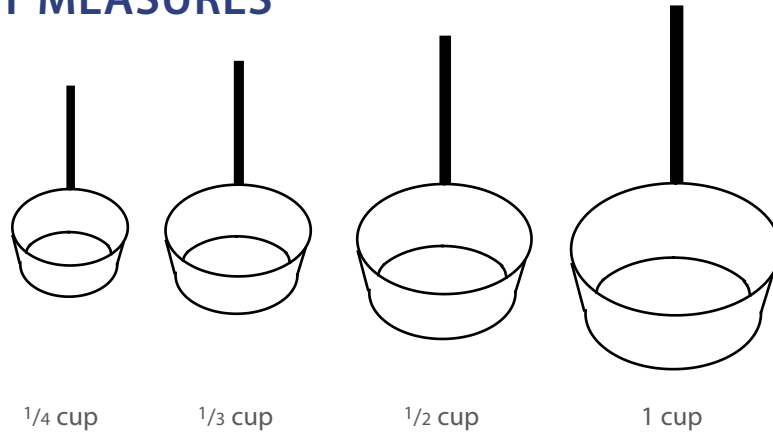

DEFINITION

Household dry measures are intended for the non-commercial measurement of dry ingredients used in preparing foods and are intended to be used level full.

CAPACITIES

Dry measures shall be of the following capacities: 2 cups, 1 cup, $\frac{1}{2}$ cup, $\frac{1}{3}$ cup, $\frac{1}{4}$ cup, and $\frac{1}{8}$ cup. A set of dry measures shall consist of a minimum of four: 1 cup, $\frac{1}{2}$ cup, $\frac{1}{3}$ cup and $\frac{1}{4}$ cup. The capacity shall be stated as the amount of material contained when level full.

GRADUATIONS AND MARKINGS

The capacity of each measure shall be identified in cup(s) and may be in terms of tablespoons based on the relations: 1 cup marked = 16 tablespoons, $\frac{1}{2}$ cup = 8 tablespoons, $\frac{1}{3}$ cup = 5 tablespoons plus 1 teaspoon, and $\frac{1}{4}$ cup = 4 tablespoons. Dry measures may be subdivided by graduation marks but into no more than $\frac{3}{4}$ cup, $\frac{2}{3}$ cup, $\frac{1}{2}$ cup, $\frac{1}{3}$ cup and $\frac{1}{4}$ cup, or their equivalents in tablespoons, or both. The word "cup" need appear only once. On a 2-cup or 1-cup dry measure, if both $\frac{1}{3}$ and $\frac{1}{4}$ cup subdivisions are used, the horizontal marks defining thirds shall be on the opposite side of a vertical line from the marks defining fourths of a cup. Subdivisions by tablespoons may be included and should be marked so as to avoid confusion with cup and fractional-cup markings. Markings on all dry measures shall be durable and distinct. The value of all markings defining graduations shall be shown and shall be no less than $\frac{3}{4}$ inch in length.

TOLERANCES

The tolerances to be allowed in excess or deficiency on customary household measures shall be $\pm 5\%$ of the designated capacity and all graduations.

CONSTRUCTION

Liquid measures shall be of sufficient strength and rigidity to withstand predictable usage with hot or cold fluids without becoming indented, distorted or otherwise damaged

MEASURING SPOONS

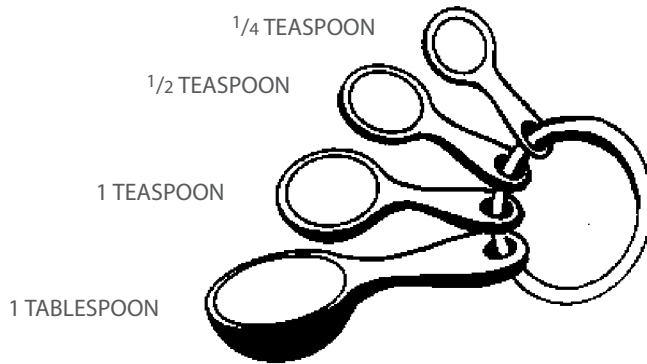

DEFINITION

Household measuring spoons are intended for the non-commercial measurement of small quantities of dry or liquid ingredients used in preparing foods.

CAPACITIES

Measuring spoons shall be of the following capacities only: 1 tablespoon, 1 teaspoon, $\frac{1}{2}$ teaspoon, $\frac{1}{4}$ teaspoon, and $\frac{1}{8}$ teaspoon. A set of spoons shall consist of a minimum of the four larger spoons. The capacity shall be stated as the amount of material contained when level full.

MARKINGS

All measuring spoons shall be marked durably and distinctly to indicate individual capacities in terms of fractional and whole teaspoons and tablespoons with no subdivision marks.

TOLERANCES

The tolerances to be allowed in excess or deficiency on customary household measuring spoons shall be $\pm 5\%$ of the designated capacity.

CONSTRUCTION

Measuring spoons shall be of sufficient strength and rigidity to withstand predicted usage without becoming dented, distorted or otherwise damaged.

Dry measures shall be of sufficient strength and rigidity to withstand predictable usage without becoming dented, distorted or otherwise damaged.

About the



The Cookware & Bakeware Alliance has been around since 1922 helping cookware and bakeware manufacturers, distributors, retailers and consumers connect and communicate.

The alliance's members are those firms that manufacturer, market and distribute a wide array of cooking, baking and kitchen utensils made of many differing materials.

The alliance provides impartial, unbiased information to consumers and retailers alike. It establishes and encourages the use of engineering standards to continually improve the quality and the manufacture of cookware and bakeware.

The Alliance is a not-for-profit entity owned by its membership.



THE COOKWARE & BAKEWARE ALLIANCE

www.cookwareandbakeware.org